



AMPD MAINTNENANCE GUIDE





MENU

i
This is an interactive PDF. Click on an icon tile and navigate to a chapter of interest.



Legal & Safety



Mixing Drum



Belts & Casters



Spray Nozzles



Premium Filter



End of Season

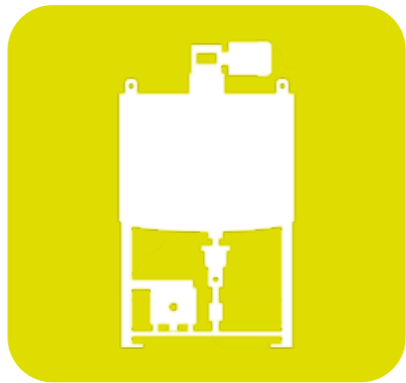

Drain PSD



Treating Head



Dry Delivery



Powder Feeder



Pictograms

Users can advance or go back single pages by using quick navigation links shown below, right.

Users can navigate to the Menu by clicking on the Menu icon shown below, left.





LEGAL & SAFETY

This manual contains technical information regarding Bayer SeedGrowth™ Equipment. Please read and understand these instructions completely before proceeding to install and operate the equipment. Bayer reserves the right to change specifications, models, components, or materials at any time without notice. For additional equipment information contact us at 1.800.634.6738. Please have this manual available when contacting Bayer.

Always use caution and common sense when working with any chemical. Read the product label and SDS carefully and follow their instructions exactly as described.

Optimal operating conditions for this piece of equipment requires an ambient temperature 32° F to +104° F (0° C to +40° C), relative humidity less than 90% (minimum condensation). Make necessary provisions to protect this piece of equipment against excessive dust, particles containing iron, moisture and against corrosive and explosive gases.

Our technical information is based on extensive testing and is, to the best of our current knowledge, true and accurate but given without warranty as the conditions of use and storage are beyond our control. Variables, such as humidity, temperature, change in seed size or variety and viscosity of chemical products can all affect the accuracy of the chemical application and seed coverage. To ensure the desired application rate and optimum seed coverage, check the calibration periodically throughout the day, and make adjustments as needed.

Any person who is involved in the installation or periodic maintenance of this equipment should be suitably skilled or instructed and supervised using a safe system of work. Isolate the treater before removing guards for maintenance.





EXPOSURE CONTROL

Always use caution and common sense when working with chemicals. Read the product label and SDS carefully and follow their instructions exactly as described. The following Personal Protective Equipment (PPE) recommendations and best practices help promote safe use in seed treatment.



Note: Exposure Control signs and labels conform to the requirements of ANSI Z535.4 or ISO 3864.



Wear protective clothing

Wear disposable or reusable coveralls with long sleeves.



Hand protection required

Wear chemical-resistant gloves.



Wear rubber boots

Wear chemical resistant rubber boots.



Labels

Label recommendations and directions for handling must be followed, including treatment procedure (use of sticker) as well as the safety requirements.



Treatment products

Keep products in a locked room that has been approved for crop protection products.



Wear a mask

Wear respiratory protection.



Eye protection required

Wear protective eyewear.



Calibration

Seed treatment equipment must be checked and calibrated regularly to ensure accurate and safe application.



Clean seed

Use well cleaned seed to avoid creation of polluted dust that will contaminate the machine, treating facility, workers, farmers and the environment during sowing.

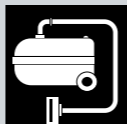

Cleaning

Use a vacuum to clean machines. Avoid using compressed air for cleaning.

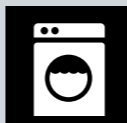

Laundry

Wash soiled reusable clothing separately. Workers must take a shower after each shift.

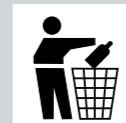

Empty containers

Non-returnable empty containers must be triple rinsed before they can be disposed. For others the recommendation of the producer must be followed.

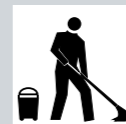

Spillage

Spillage must be avoided; it must be thoroughly cleaned up to avoid contaminating the environment and waterways.



Maintenance

Keep machinery clean between treating sessions.





REFERENCE SYMBOLS

Symbols and signal words are used to identify the level of hazard and help avoid personal injury.



Note: Safety signs and labels conform to the requirements of ANSI Z535.4 or ISO 3864.



Shock Hazard

Alerts that dangerous voltage may be present.



Warning

Alerts that a hazard may cause serious injury or death.



Caution

Alerts that a hazard may cause minor or moderate injury.



Hand crush - moving parts

Alerts crushing is possible.



Pinch point

Keep hands away from pinch points.



Rotating shaft

Do not wear loose clothing around turning parts.



Disconnect

Disconnect to de-energize before opening.



Use guards

Keep guards in place. Do not remove during operation.



Lifting

Requires two people to safely lift an item.



Lift points

Requires the use of proper rigging and lifting techniques based on the lift plan.



Center of gravity

Indicates the center of gravity of the machine to help assist when rigging and lifting.



Tools

Required tools for installation and maintenance.



Parts

Required parts for installation and maintenance.



Tip

Calls attention to special information.



Note

Emphasizes general information worthy of attention.



Example

Provides a problem or exercise that illustrates a method or principle.





PICTOGRAMS

i

Each Signifier displayed here is specific to this User Manual.

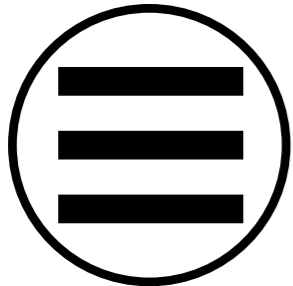

Menu



Previous



Advance



Treating Head



Dry Delivery



Powder Feeder



Mixing Drum

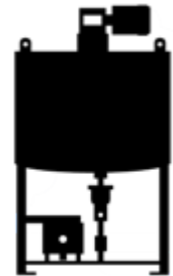

PSD Tank



Belts & Casters



Spray Nozzles



Premium Filter

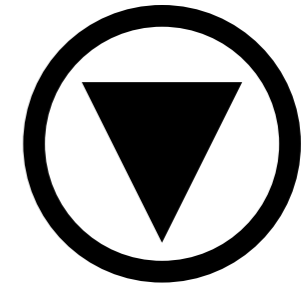

End of Season





MIXING DRUM



Warning! Exercise extreme caution when working with chemicals! Wear proper PPE >>



Required tools

- Quarter Turn Key
- Vacuum
- Putty knife

Mixing Drum & Doghouse

Completely clean the Mixing Drum and Dog House.

- Prior to switching varieties, seed types or seed sources.
- Use the factory supplied Quarter Turn Key to unlatch the door, tilt back and remove the Access Door from the discharge end of the Drum.

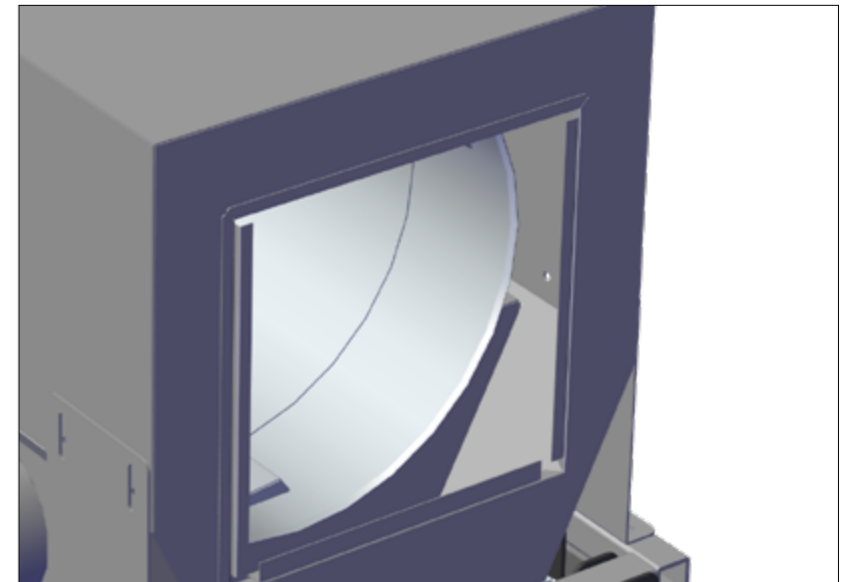
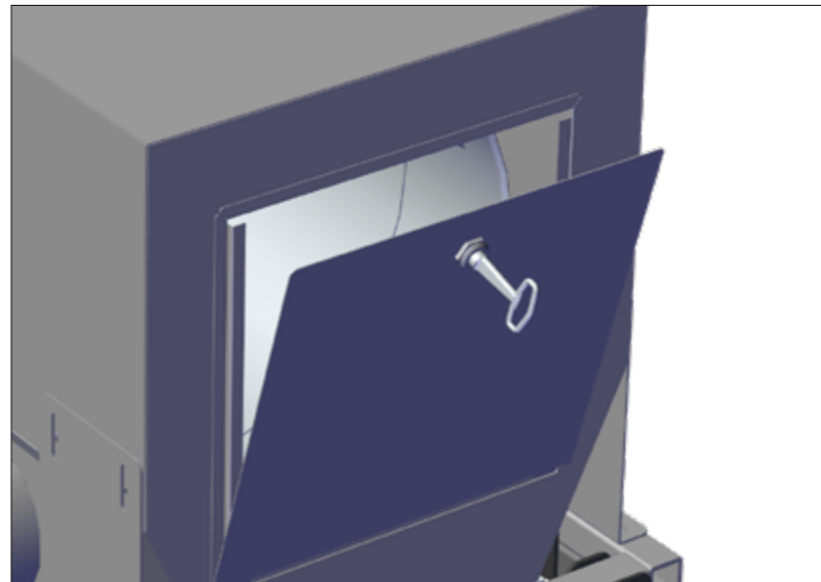
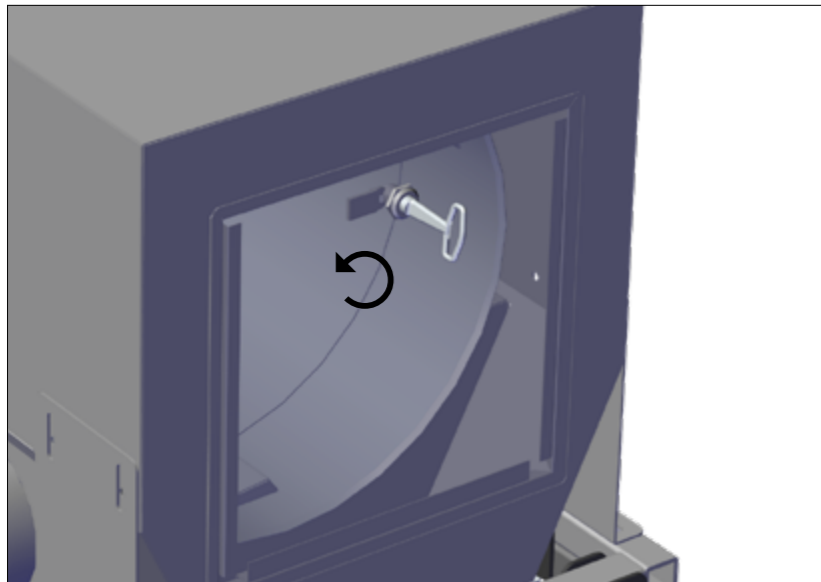

- Always use a vacuum (not compressed air) to safely clean the Mixing Drum and Doghouse of residual seed and dust.
- Replace the door and lock in place when finished cleaning the Mixing Drum and Doghouse.

This completes the Mixing Drum and Dog House cleaning procedure.





BELTS & CASTERS

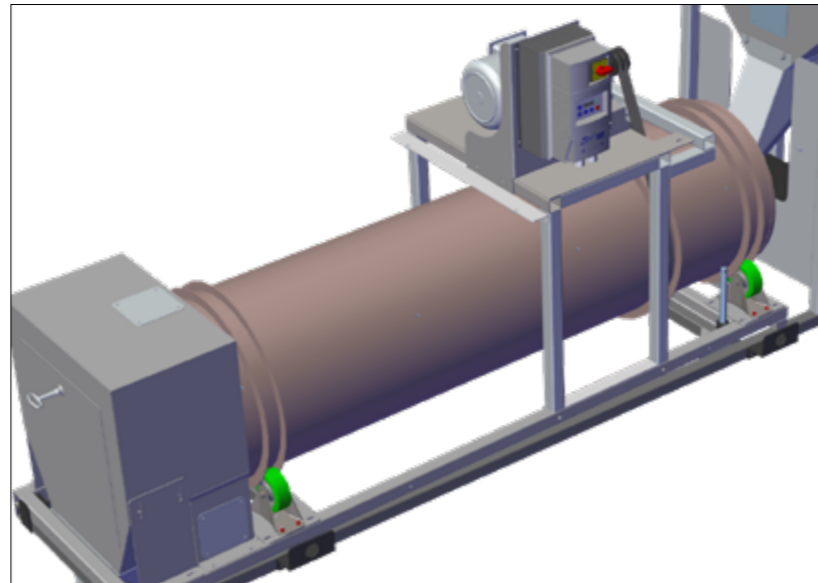
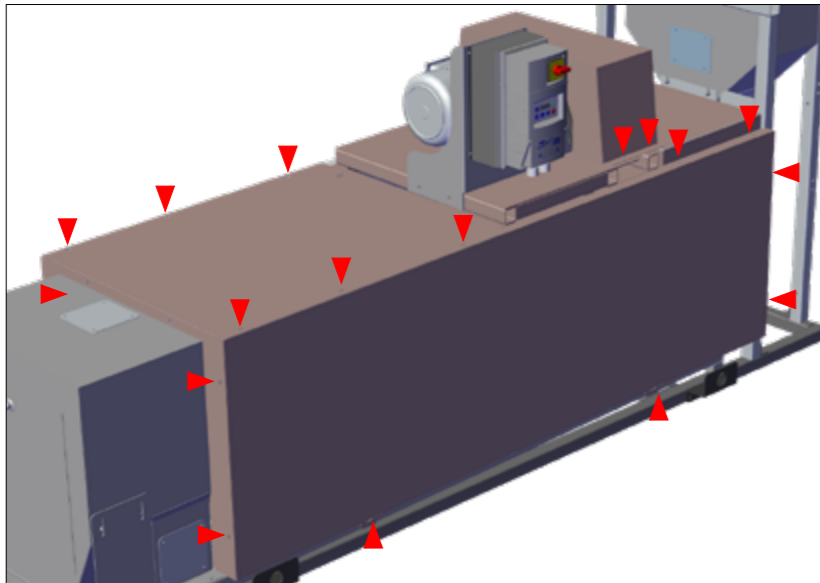

Required tools

- 7/16" wrench
- 1/2" wrench
- 9/16" wrench
- Crescent wrench
- Slotted Screwdriver

Replace belts

Step 1: Use a 7/16" wrench to remove Drum and Motor Belt Guarding Access panels.

- Also remove the two (2) tabs along the bottom of the Drum Frame.

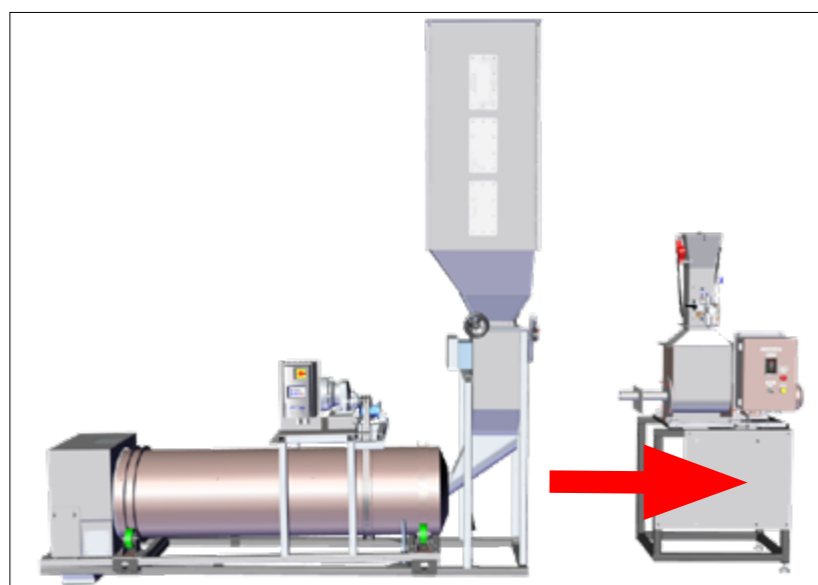
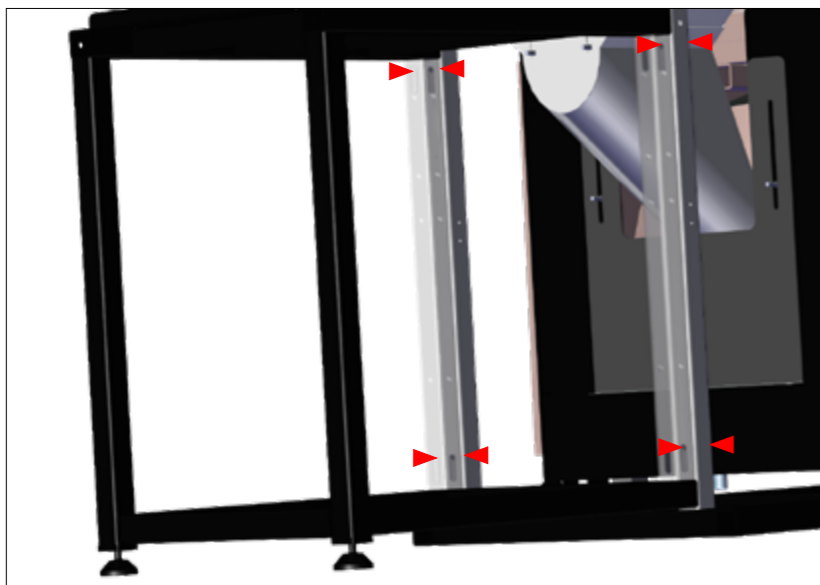

Step 2: Remove the Dry Delivery System from the Treater frame.

- Use a 1/2" socket head wrench to remove four pair of factory supplied 5/16" hardware used to fasten the Powder Assembly to the Drum Frame in this order.
- Remove the Dry Delivery System from the Treater Frame.

Continued ➡



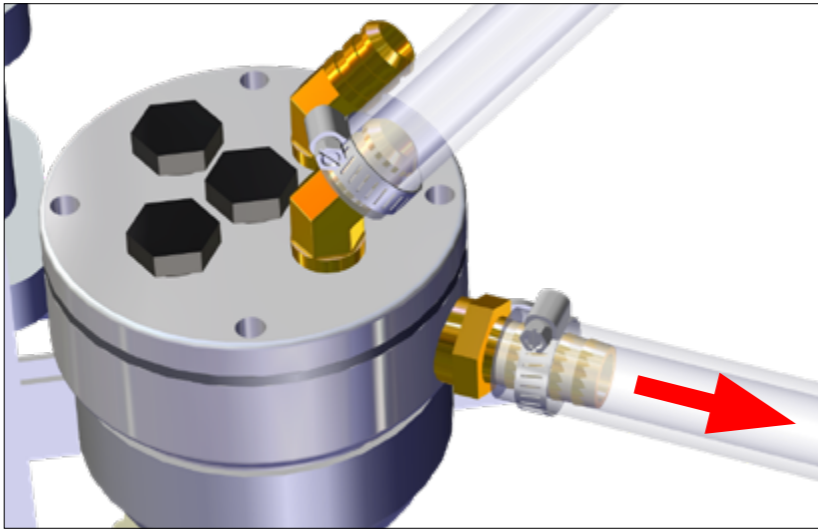

Step 3: For liquid systems, use a slotted screwdriver to disconnect the feed tube from the Positive Pressure System Reservoir Cup brass barb fitting.

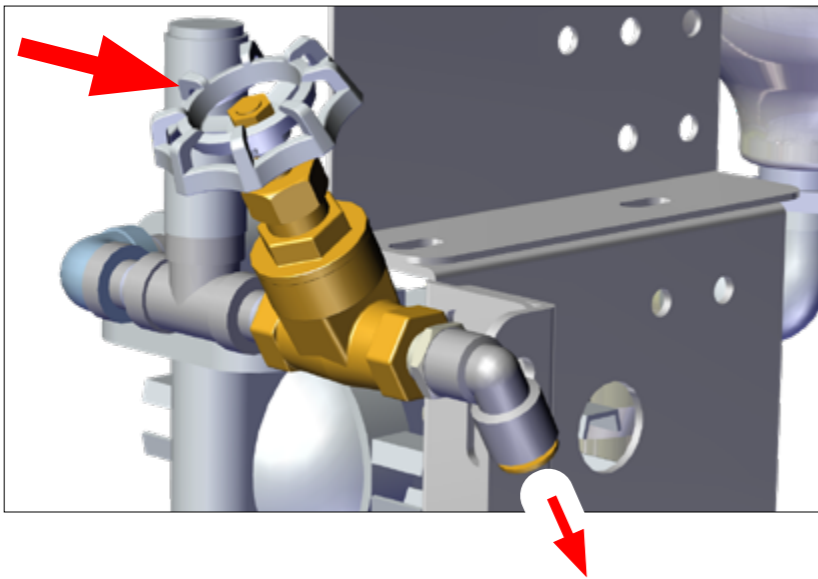

Step 4: Then close the Gate Valve and push the orange fitting tab in and pull out the feed tube from the Gate Valve Press Lock Fitting.

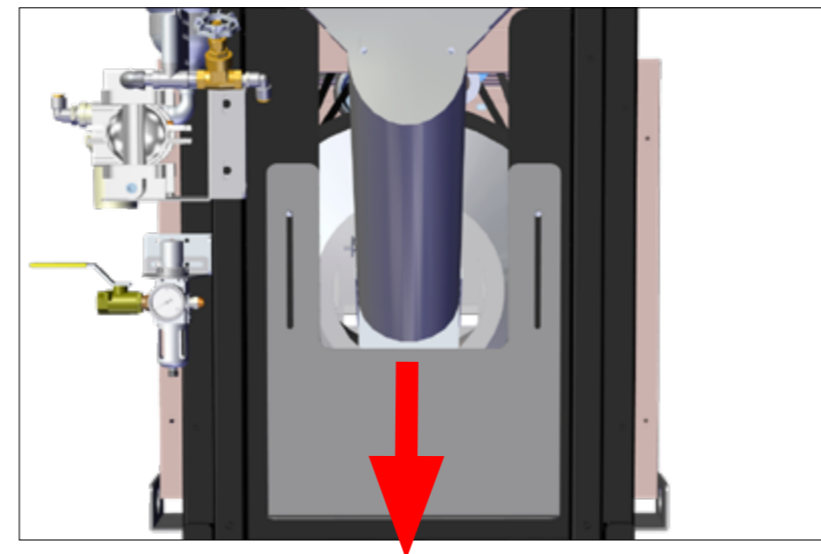
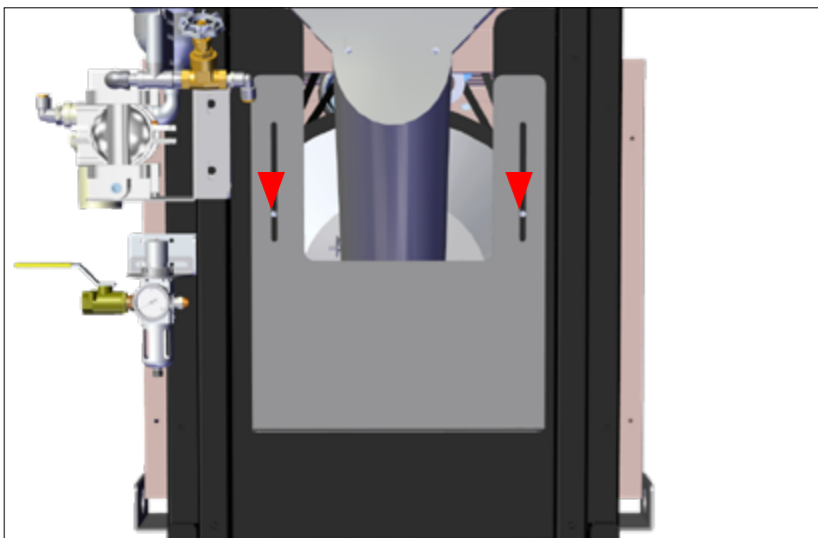

Step 5: Loosen the two (2) wing nuts that hold the Transition Guard in place.

- The Guard will slide down (slotted).

Continued ➞



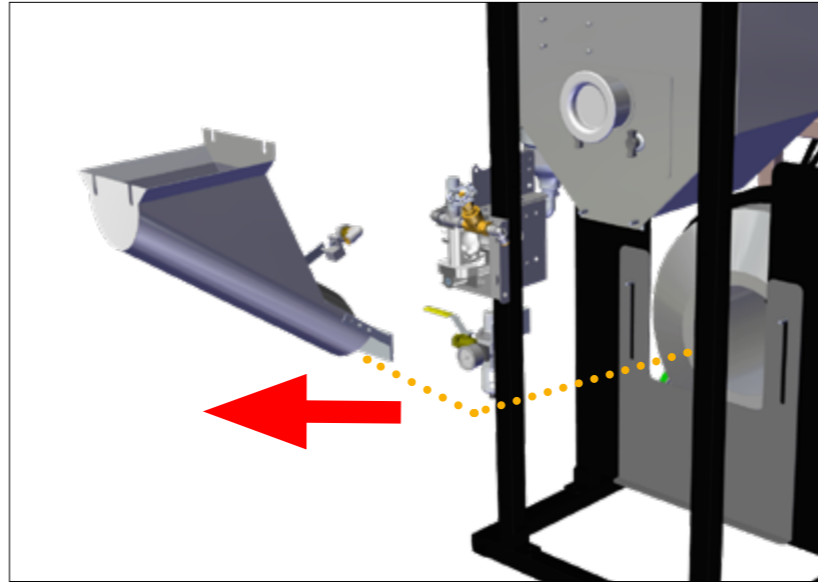
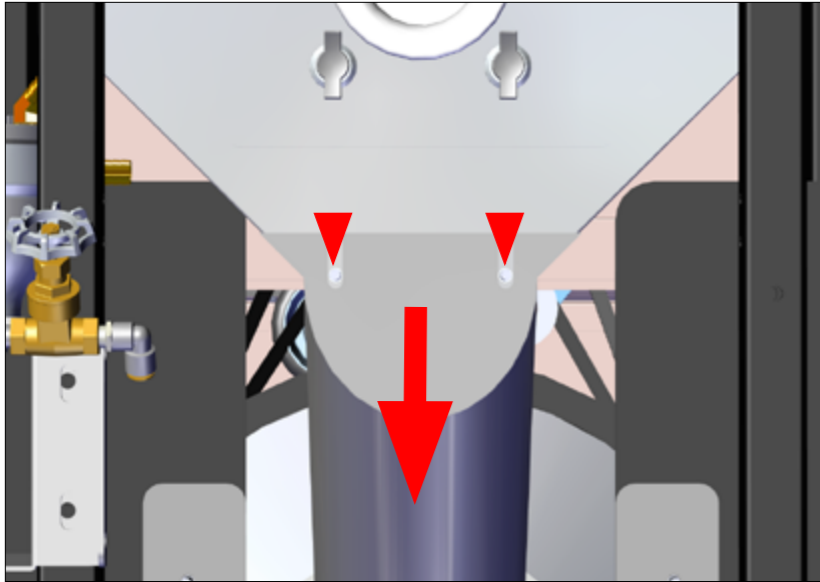

Step 6: Loosen the two (2) wing nuts that hold the Transition in place.

- The Transition will drop down.
- The Spray Nozzle and tubing will remain attached.
- Remove from inside the Drum and set aside.

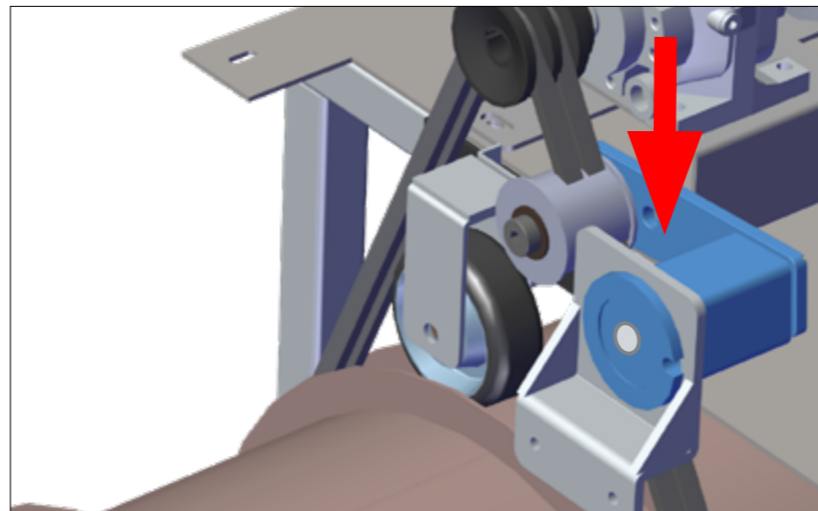
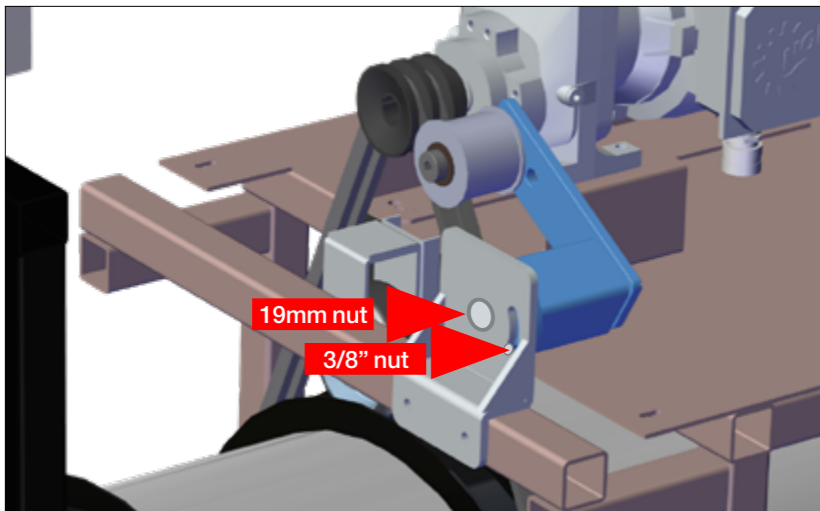

Step 7: Use a 9/16" wrench to remove the 3/8" nut holding the tensioner in place.

- Then use a crescent wrench to loosen the 19mm tensioner nut.
- This loosens the tension applied to the Drum belts.

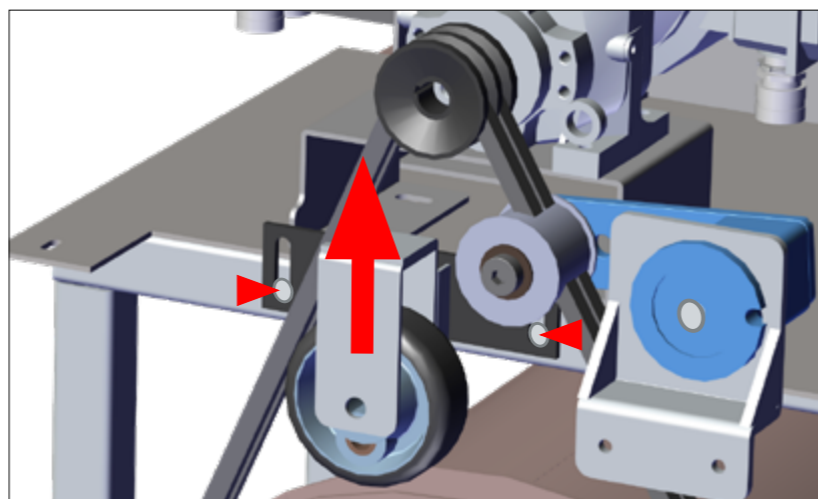
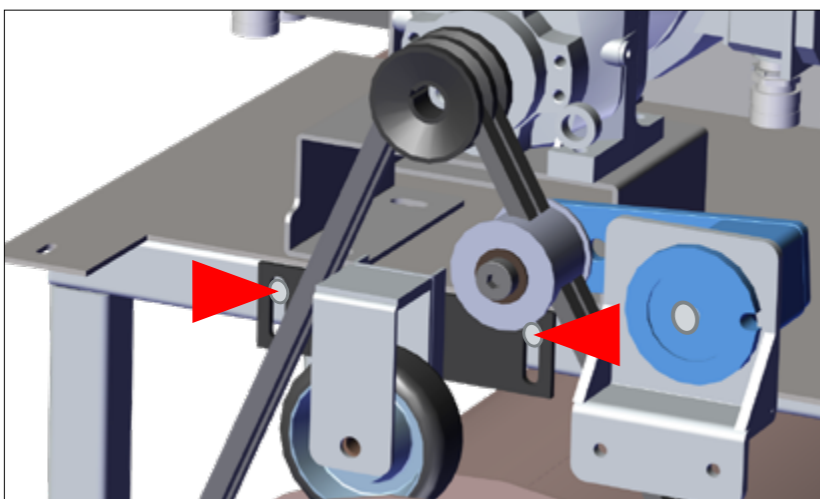

Step 8: Use a 1/2" wrench to loosen both 5/16" adjustment nuts on the Idler Wheel Bracket holding the drum down on top of the Drum frame Casters.

- Move the bracket all the way up and hand tighten both nuts to hold the bracket in place.
- This loosens the tension applied to the Drum.

Continued ➞





Step 9: REQUIRES TWO PEOPLE!

Lift the Drum up by hand (about an inch) and slip the V-belts off the pulleys and from around the back (inlet end) of the Drum.

- Replace worn or cracked V-belts from the Parts Kit shipped with the treater.
- Reverse order to replace all parts (refer to pages 5-8, Steps 1-9).

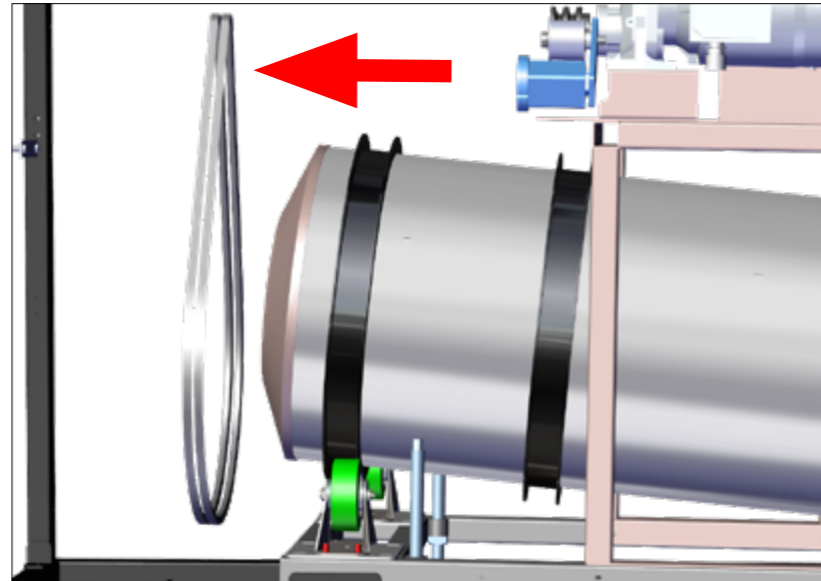
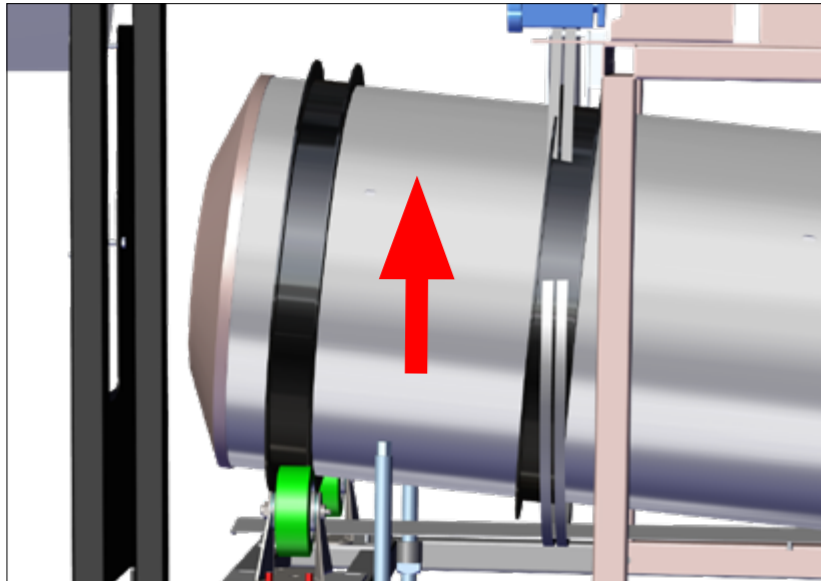

Note: at this time (with the drum lifted up off the casters) check the casters for wear. Replace them if needed.

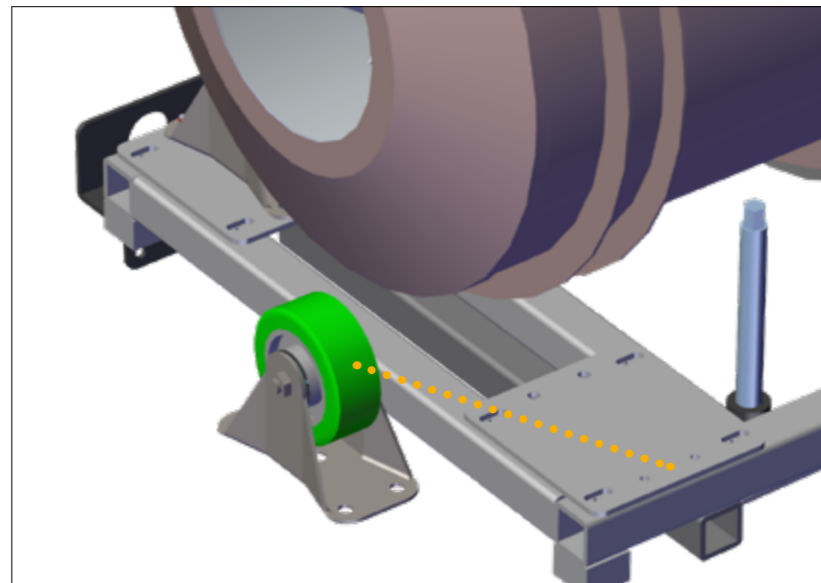
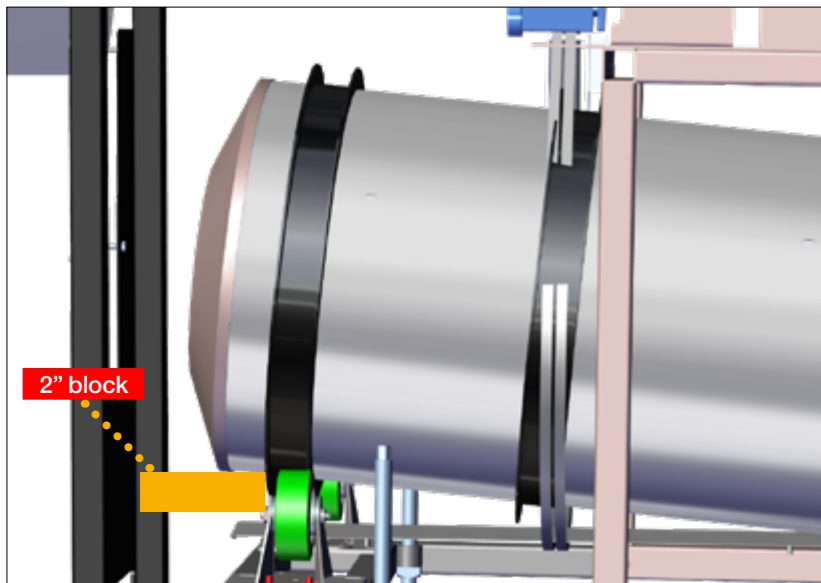
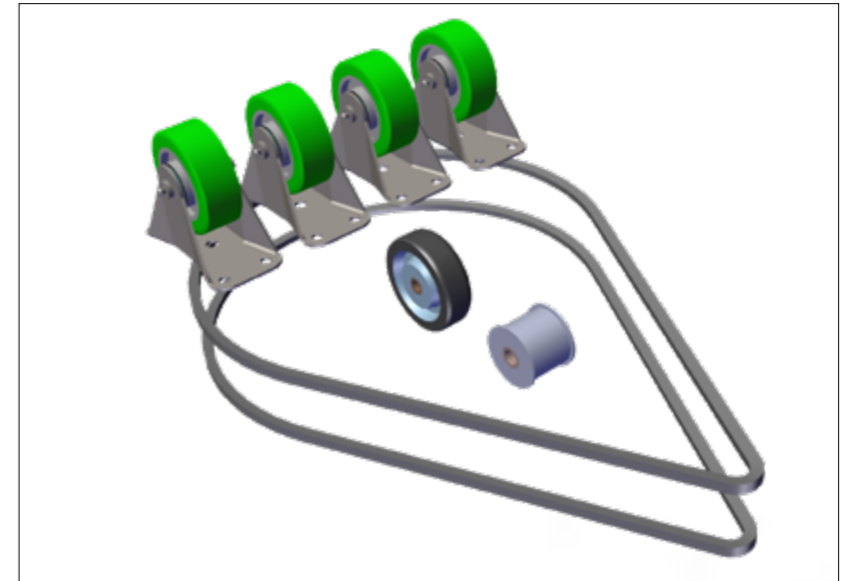

Step 10: To replace Casters, when the drum tension is still loose (previous steps 7 - 9) place a two (2) inch block underneath the drum to hold it in place.

- Use a 1/2" wrench to remove four (4) 5/8" nuts holding the caster on the frame underneath the drum.
- Replace the caster and fasten in place with the same hardware.
- Reverse order to replace all parts (refer to pages 5-8, Steps 1-9).

This completes the Belts & Casters replacement procedure.





SPRAY NOZZLE

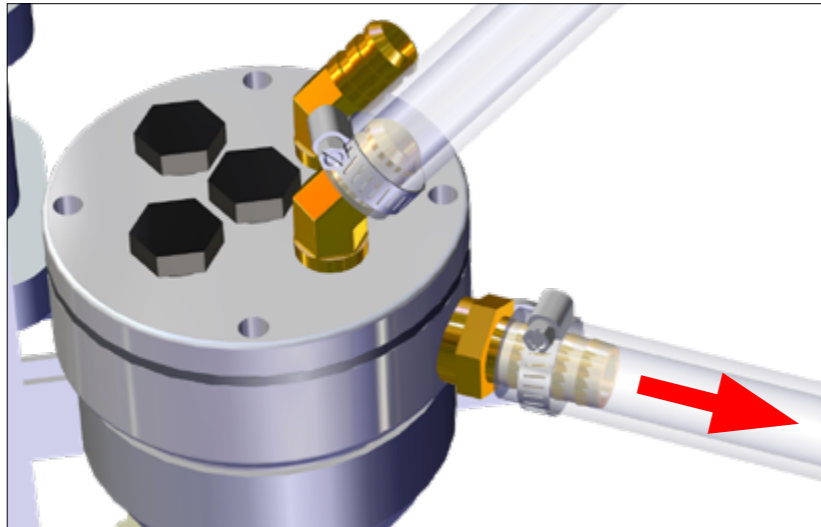

Replace spray nozzles - Liquid Systems

Step 1: To change out a replacement spray nozzle, use a slotted screwdriver to disconnect the feed tube from the Positive Pressure System Reservoir Cup brass barb fitting.



Required tools

- Slotted Screwdriver
- 7/16" wrench

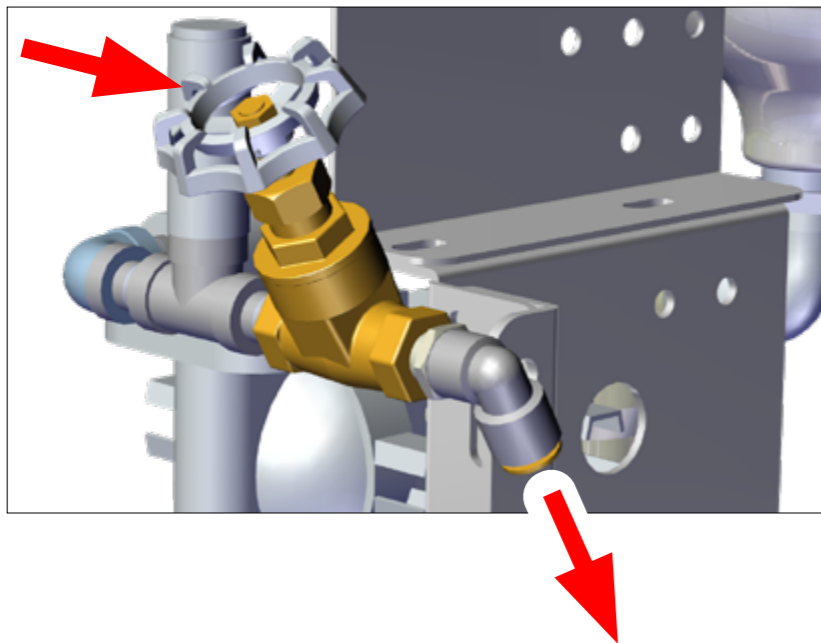

Step 2: Then close the Gate Valve and push the orange fitting tab in and pull out the feed tube from the Gate Valve Press Lock Fitting.

Continued ➞



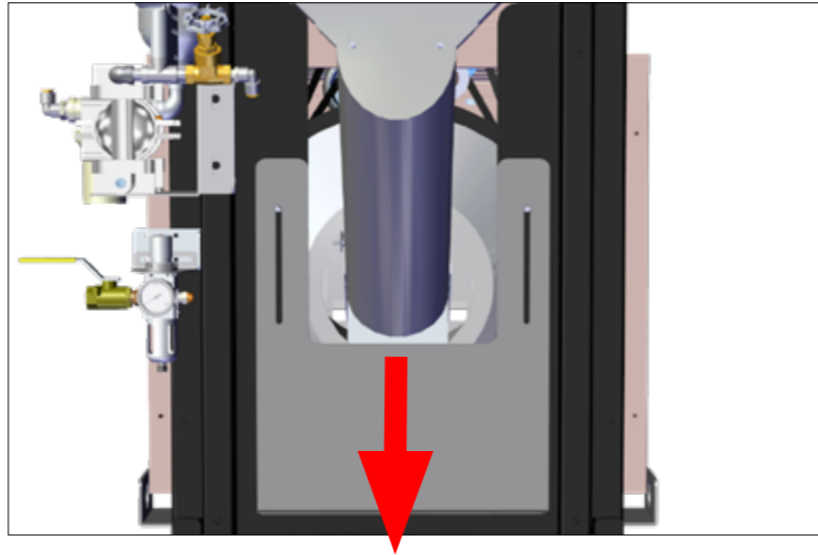
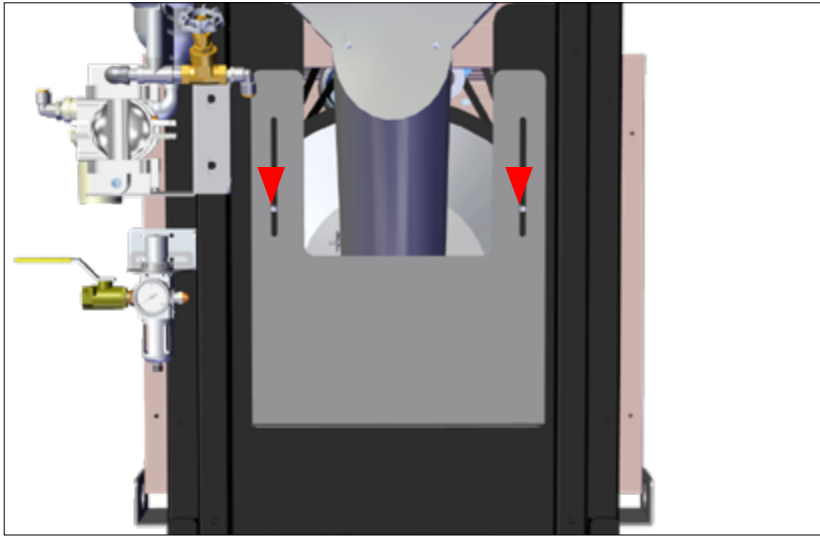

Step 3: Loosen the two (2) wing nuts that hold the Transition Guard in place.

- The Guard will slide down (slotted).

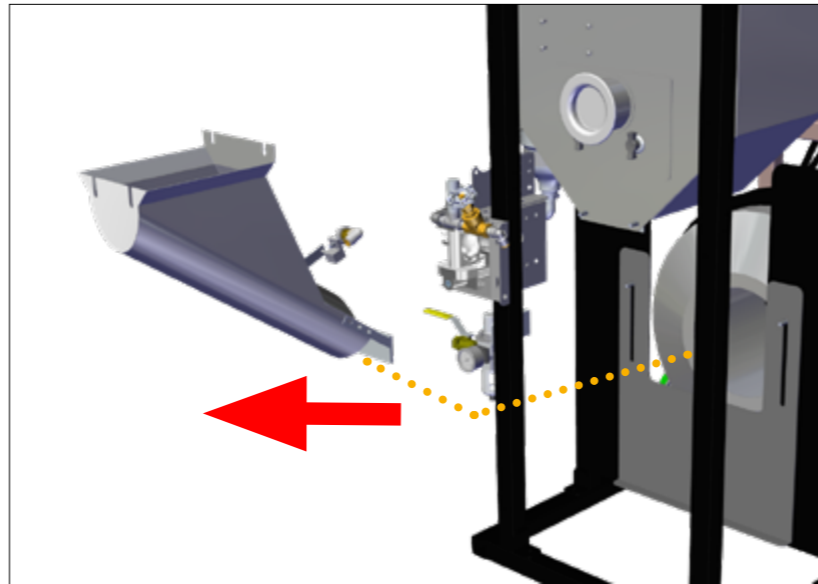
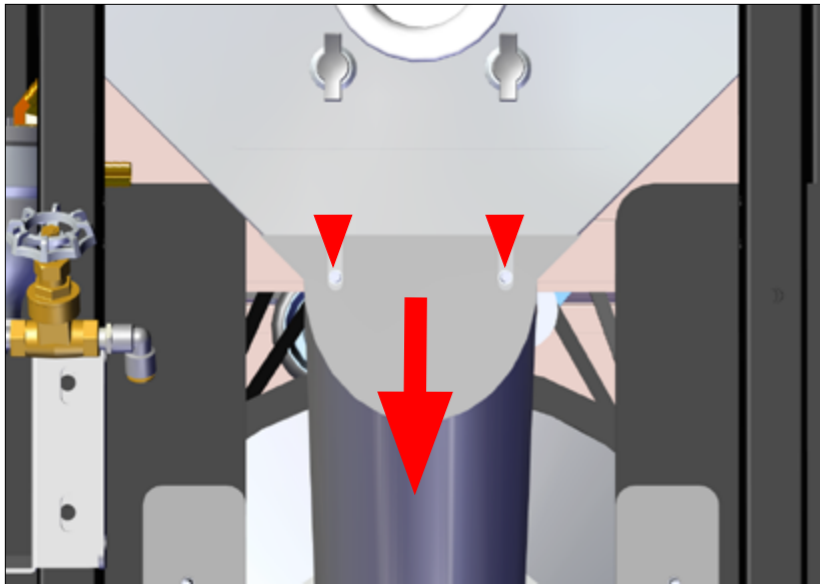

Step 4: Loosen the two (2) wing nuts that hold the Transition in place.

- The Transition will drop down.
- The Spray Nozzle and tubing will remain attached.
- Remove from inside the Drum and set aside.

Continued ➞



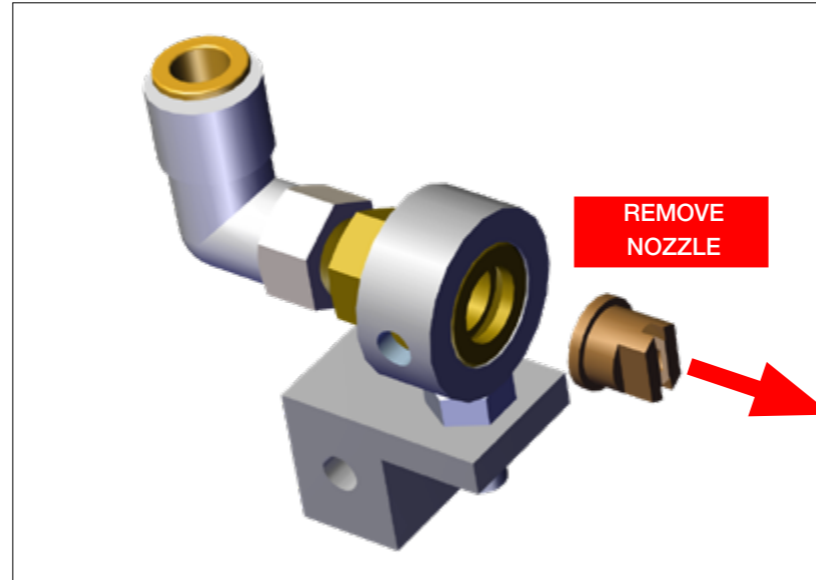
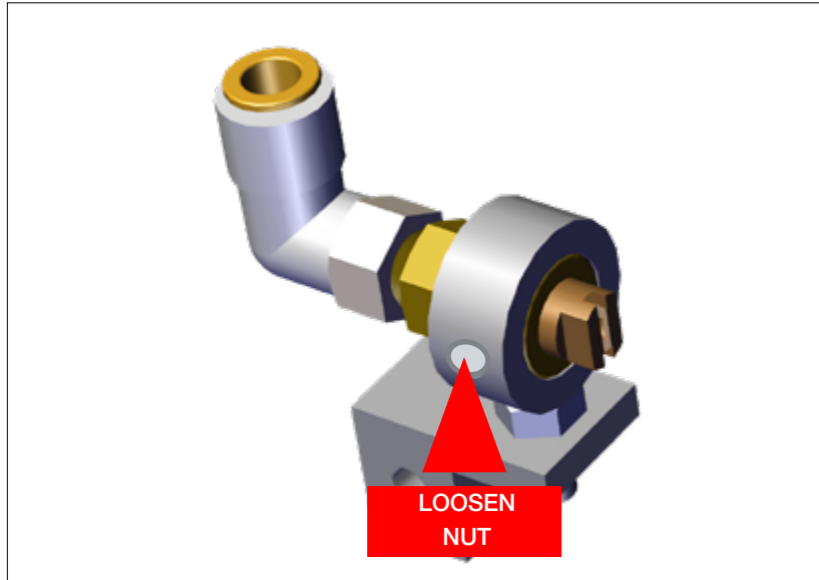

Step 5: Use a 7/16" wrench to loosen the nut on the side of the Nozzle Holder.

- Remove the Nozzle and replace with new one.
- Refer to the Nozzle Selection Guidelines below.
- Insert a new Nozzle and tighten the nut.
- Best practice is to follow this procedure and periodically check or clean the Nozzle.
- Reverse order of steps 1-4 to replace all parts.

This completes the Spray Nozzle replacement procedure.

Nozzle Selection - Suggested Guidelines

Spray nozzle design determines the spray droplet pattern. Nozzle flow rates vary with spraying pressure. Seed volume + chemical viscosity + chemical application rate + air temperature can all affect the final outcome of the spray droplet pattern and overall seed coverage.

Begin treating with the factory-supplied medium nozzle **8015**.

Small nozzle (8006) fog or mist of fine droplets resulting in fair seed coverage covering minimal amount of seed.

Large nozzle (8030) blotchy dribbles and a waterfall effect resulting in poor coverage covering very little seed.

Medium nozzle (8015) fan spray resulting in wide spray pattern and good coverage covering maximum seed.

Low volume treating (400bu/hr + 4oz/cwt application rate) the small nozzle (8006) may be the best choice.

Medium volume treating (600bu/hr + 6oz/cwt application rate) the medium nozzle (8015) may be the best choice.

High volume treating (800bu/hr + 12oz/cwt application rate) the large nozzle (8030) may be the best choice.





PSD PREMIUM FILTER

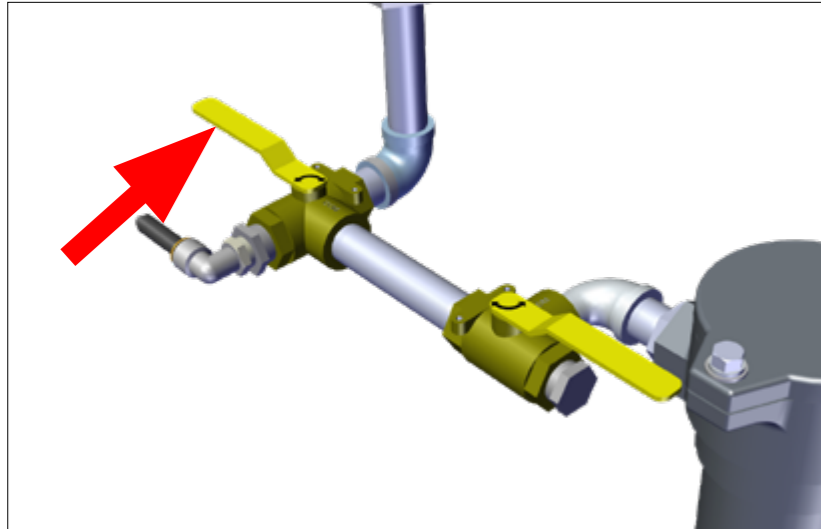

PSD Tank - Premium Filter

Step 1: Close the Main Supply Ball Valve (located underneath the Supply Tank).

- Check filter periodically for clogging issues.



Required tools

- 9/16" wrench

Step 2: Use a 9/16" wrench to remove the Cover from the Basket.

- Remove the gasket O-ring and check for cracks or wear, replace if needed.

Continued ➞

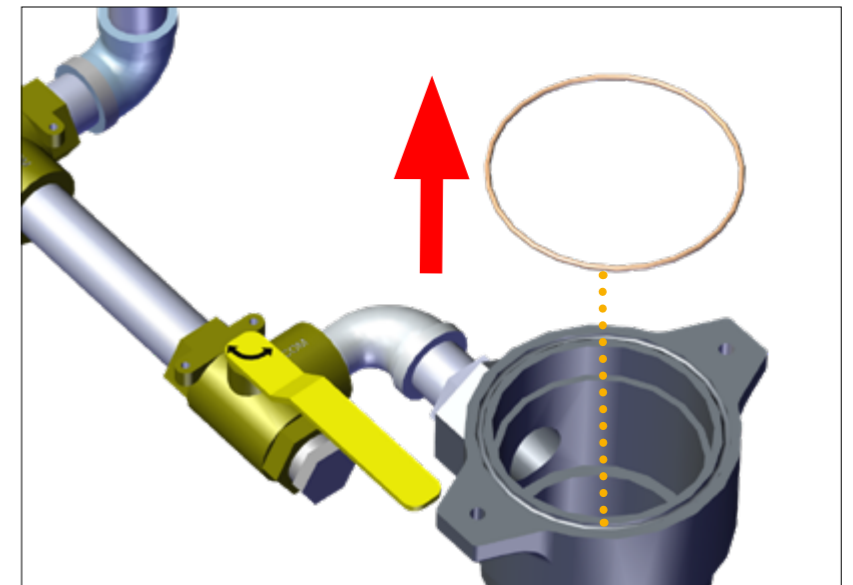
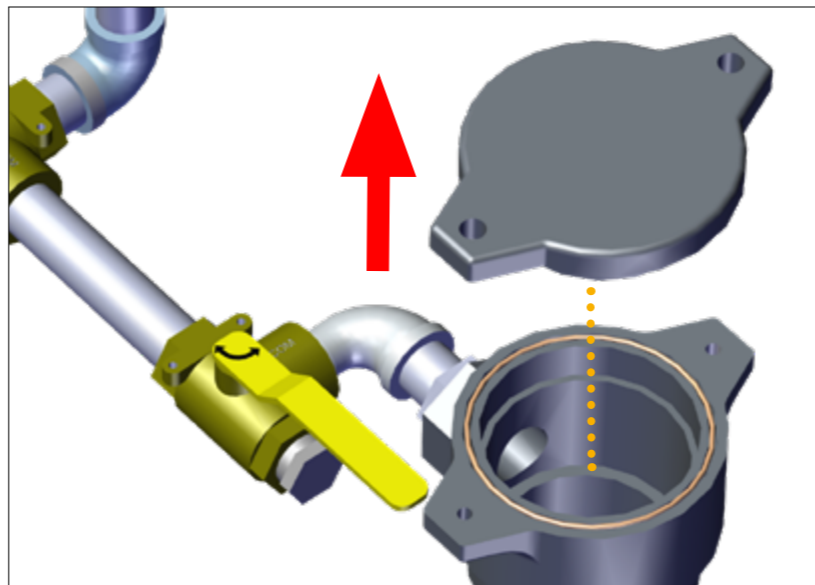
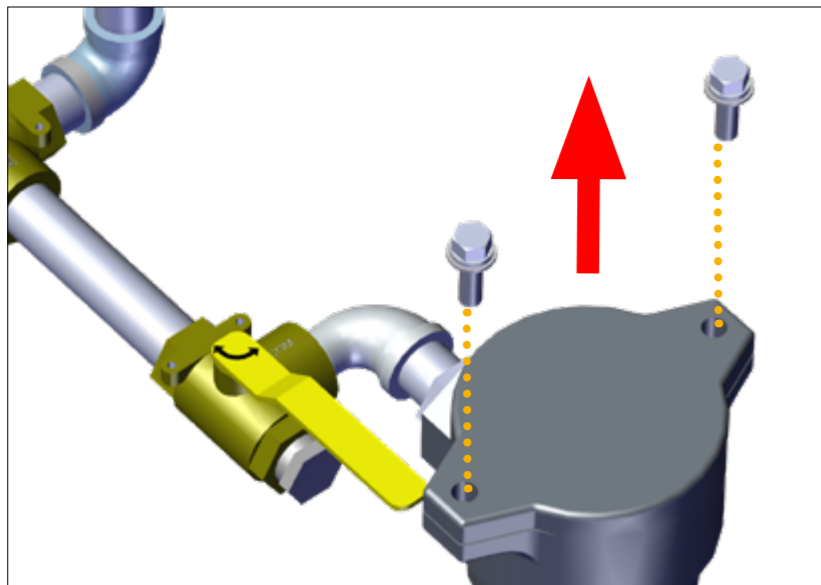

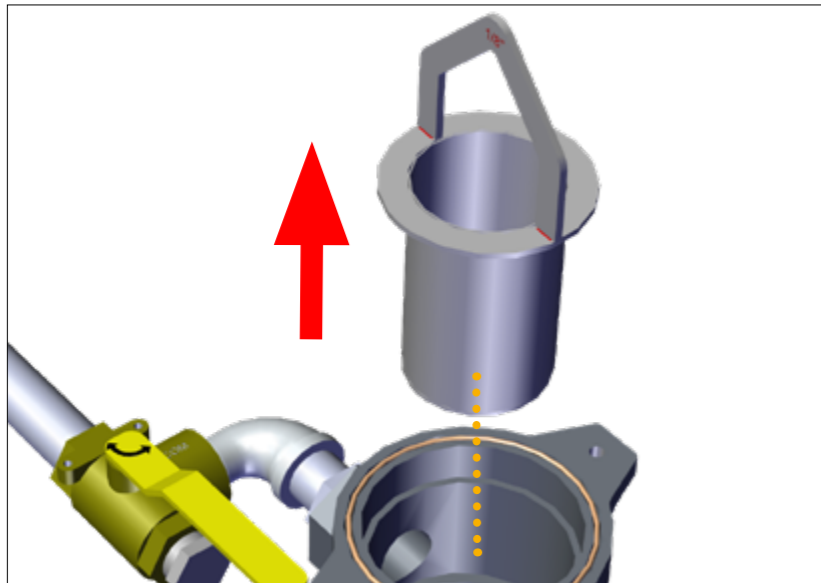

Step 3: Remove the Filter from the basket.

- Clean Filter thoroughly and replace in the Basket.

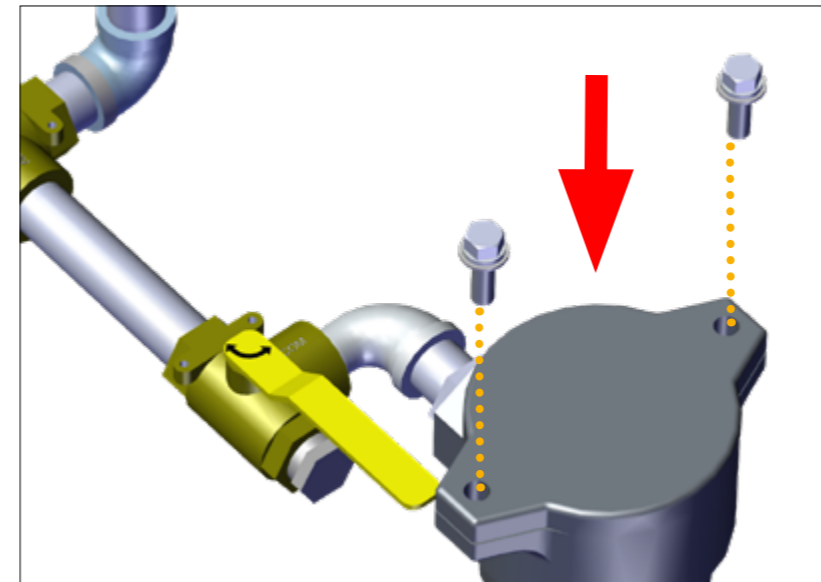
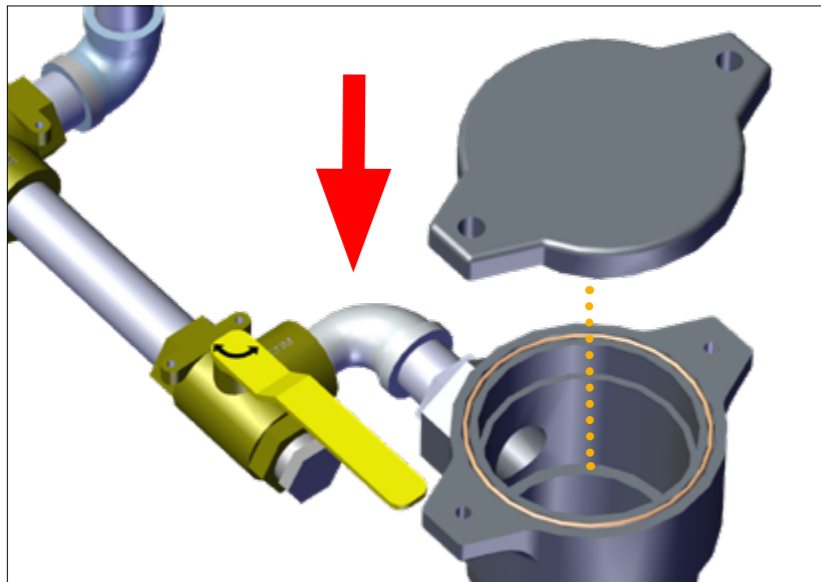

Step 4: Replace the Cover on the filter Basket.

- Use a 9/16" wrench to tighten the two bolts on the Basket.

This completes the PSD Premium Filter cleaning procedure.





END OF SEASON - RINSE

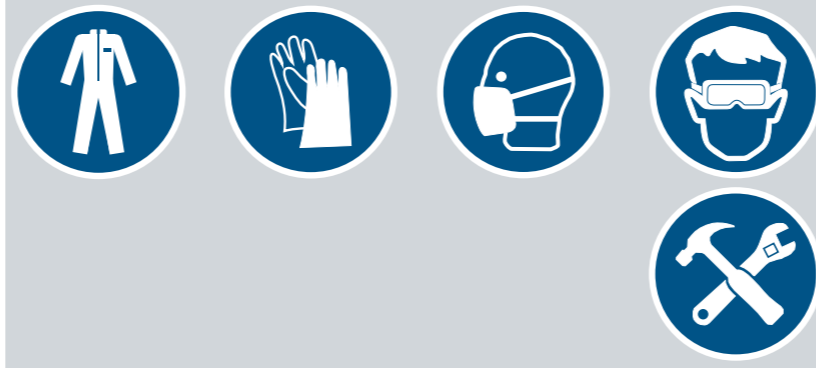

Required tools

- 7/16" wrench

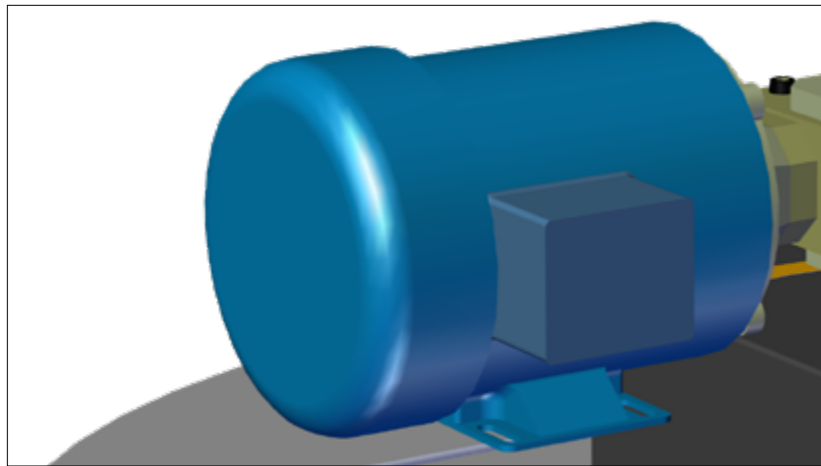

End of Season Shut-down Rinse

Step 1: Connect the PSD Tank Agitation Power Cord to an external power source.

- Tank agitation begins when power cord is connected to power.

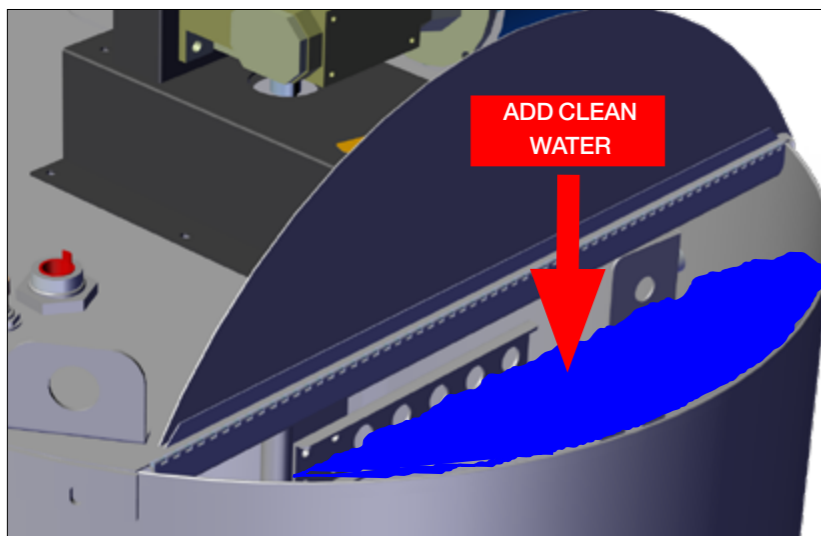

Step 2: Open the Hinged Cover Lid and fill the Supply Tank with clean water.

- Allow water to agitate for a few minutes.

Continued ➞



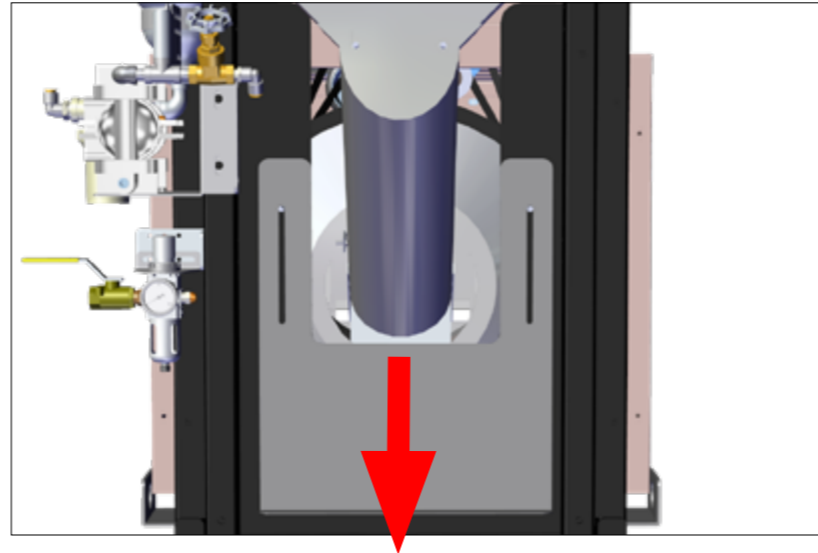
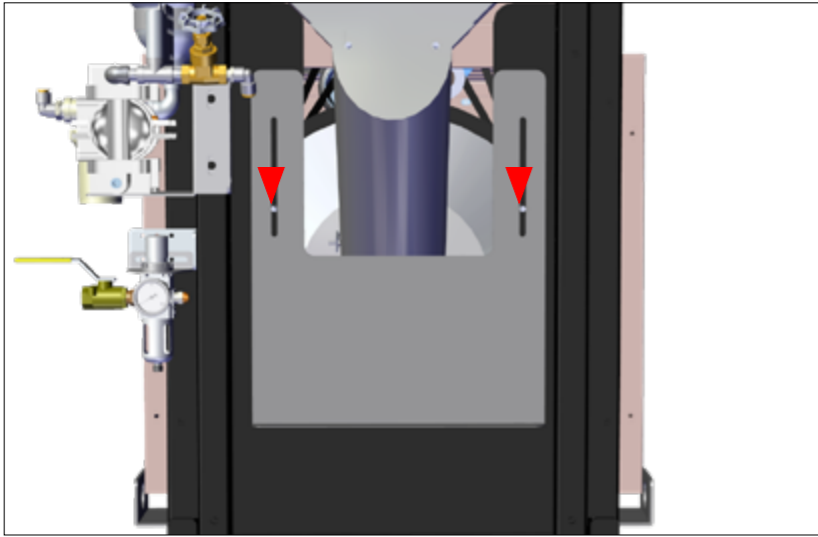

Step 3: Loosen the two (2) wing nuts that hold the Transition Guard in place.

- The Guard will slide down (slotted).

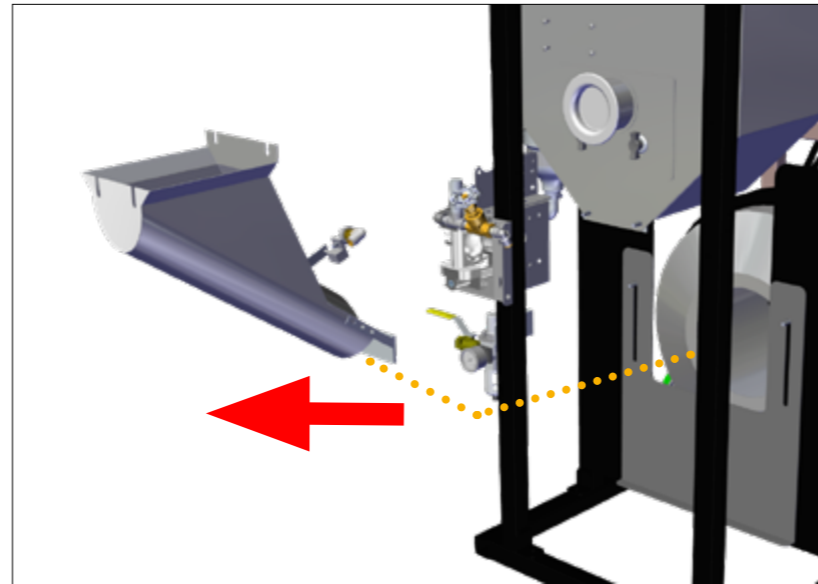
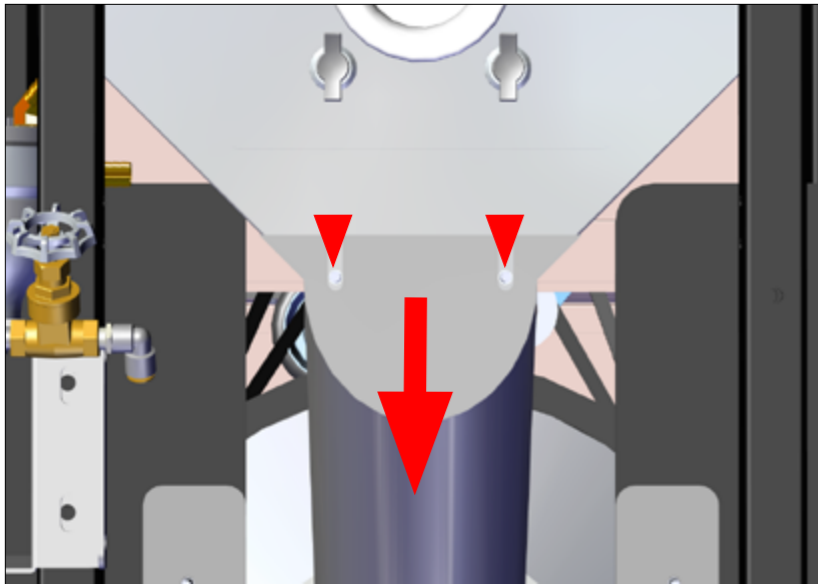

Step 4: Loosen the two (2) wing nuts that hold the Transition in place.

- The Transition will drop down.
- The Spray Nozzle and tubing will remain attached.
- Remove from inside the Drum and set aside.

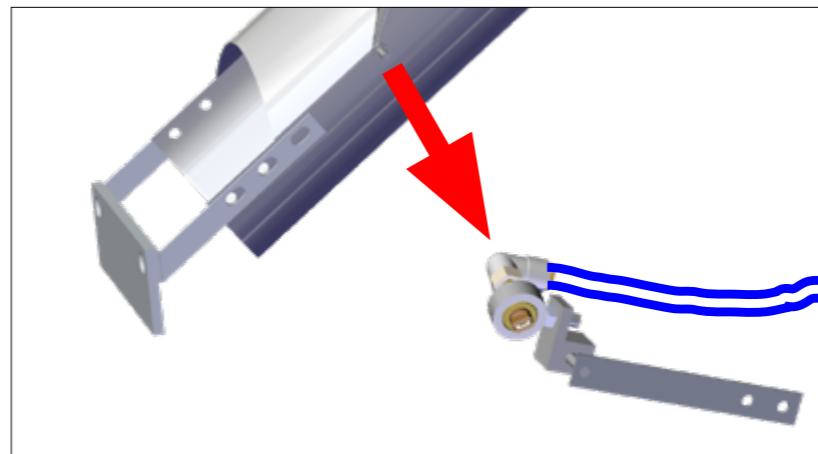
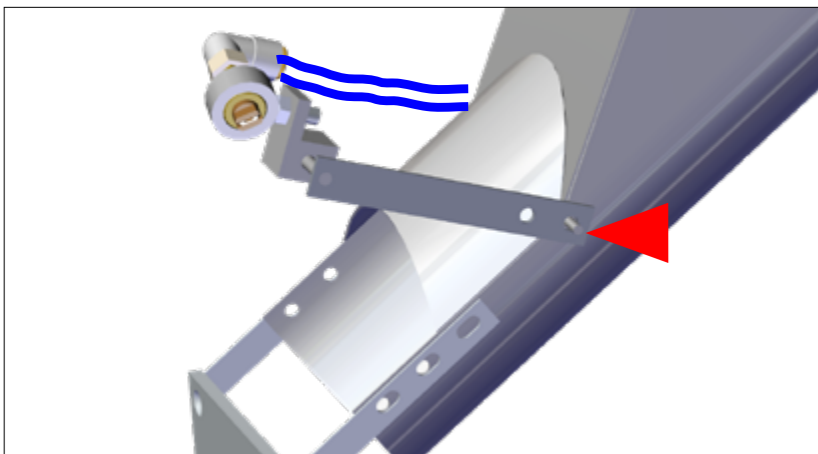

Step 5: Use a 7/16" wrench to loosen the nut and remove the Spray Nozzle Assembly from the Transition.

- Place the Spray Nozzle Assembly in a large container (at least a five gallon bucket).
- Tubing will remain attached.

Continued ➡



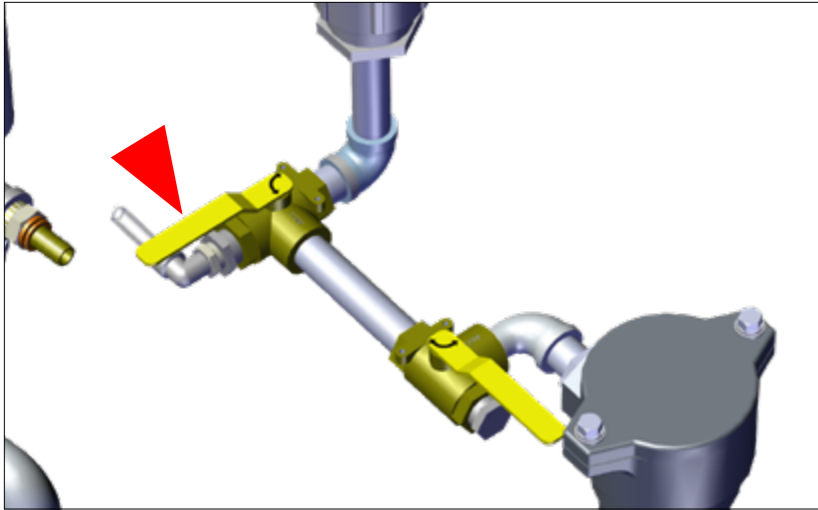

Step 6: Open the Main Supply Ball Valve (located underneath the Tank).



Note: Rinse water (gray water) from supply tank clean out procedures may be saved and used with the next slurry mix or disposed of properly, according to state and local regulations.

Failure to clean the supply tank properly, or failure to completely drain all liquid from the pump and lines after use, may damage the equipment and void any warranties expressed or implied.

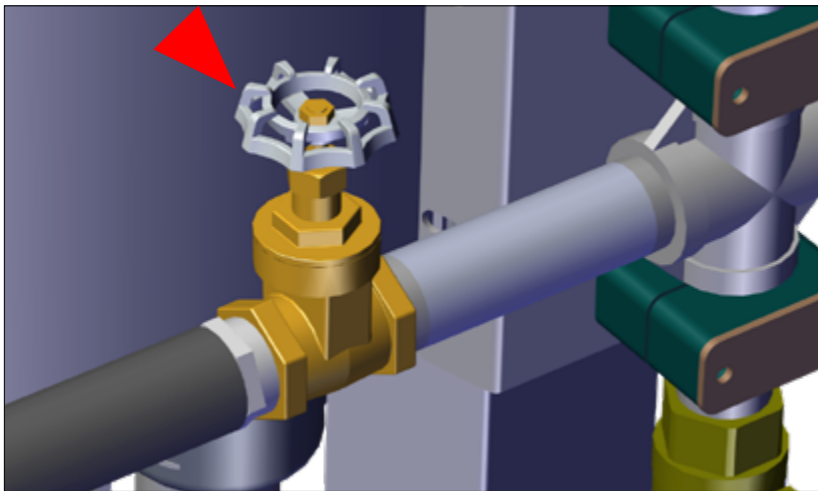

Step 7: Open the Gate Valve on the PSD Supply Tank.

- Dispenses water from the Supply Tank, into the Metering Tank and Overflow Tubes.



Step 8: Manually trip the Counterweight Arm from side to side.

- This action dispenses water from the Metering Tank into the funnel, out through the Spray Nozzle Assembly and into the waste receptacle.
- Continue tripping the Counterweight Arm until the bucket is full and the dispensed water turns clear.

Continued ➞



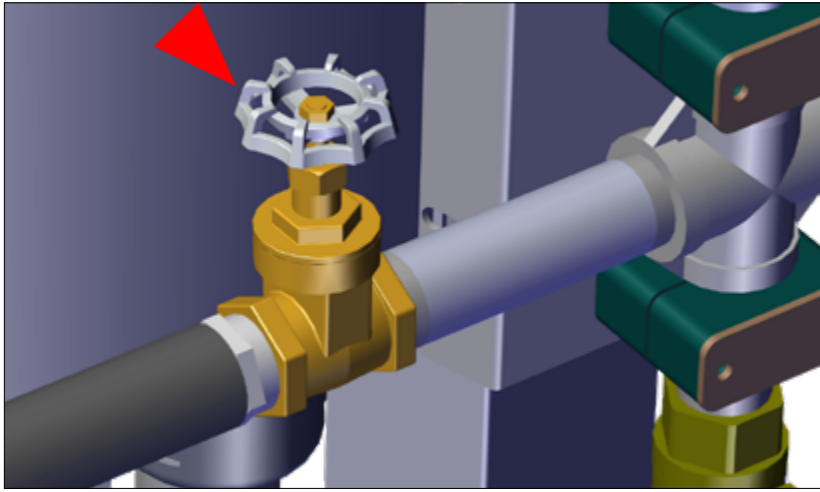

Step 9: Close the Gate Valve on the PSD Supply Tank.

- Keep the gray water in the PSD Tank to be used to flush out the tank in the next section: Drain PSD Tank.

This completes the End of Season Rinse procedure.





DRAIN PSD TANK

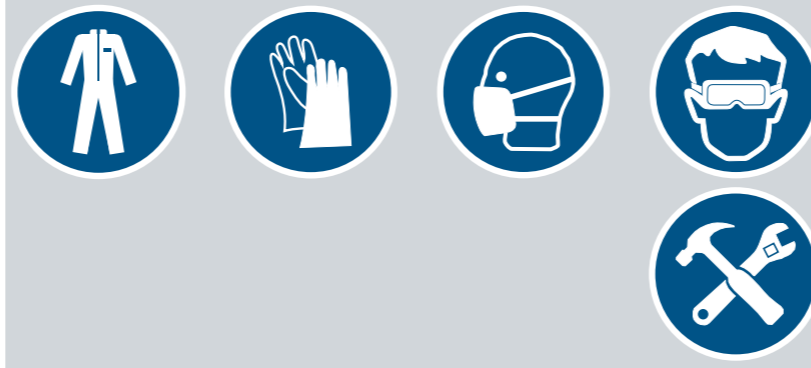

Required tools

- Crescent Wrench

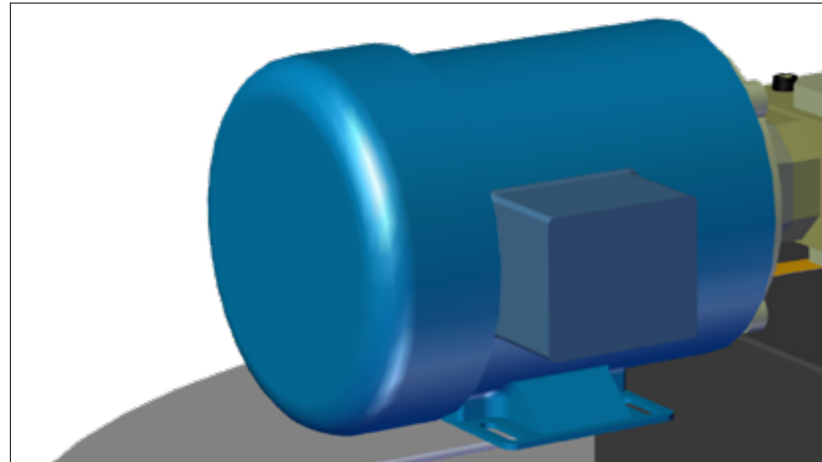

Drain PSD Supply Tank

Step 1: Connect the PSD Tank Agitation Power Cord to an external power source.

- Tank agitation begins when power cord is connected to power.

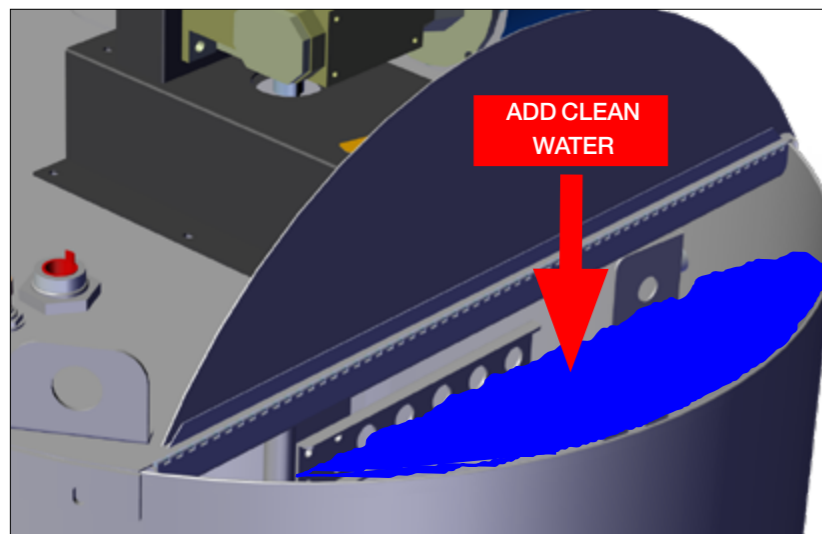

Step 2: Open the Hinged Cover Lid and fill the PSD Supply Tank with clean water.

- Can use the gray water from previous section: End of Season Flush (refer to page 17).
- Allow water to agitate for a few minutes.

Continued ➞



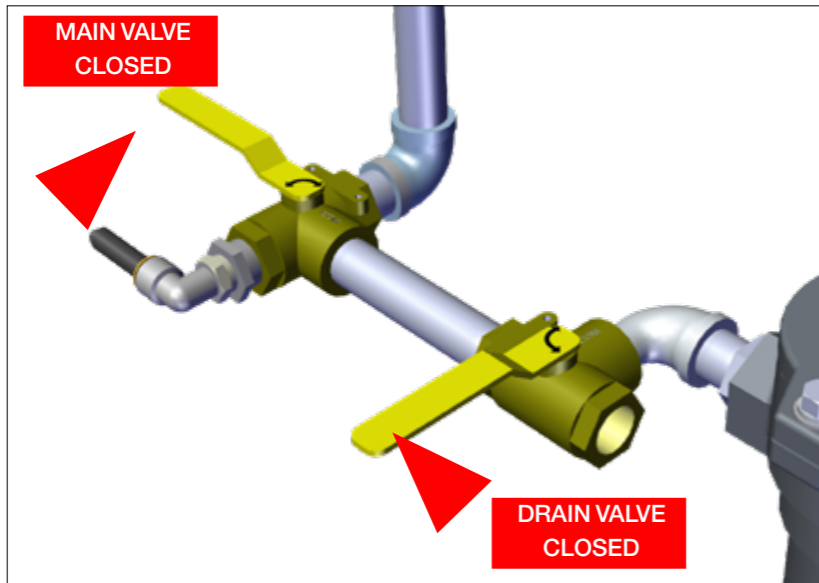

Step 3: Close the Main Supply Valve under the Supply Tank.

- Close the Drain Valve.
- **DO NOT RUN DISPENSED WATER INTO A SEWER DRAIN!**

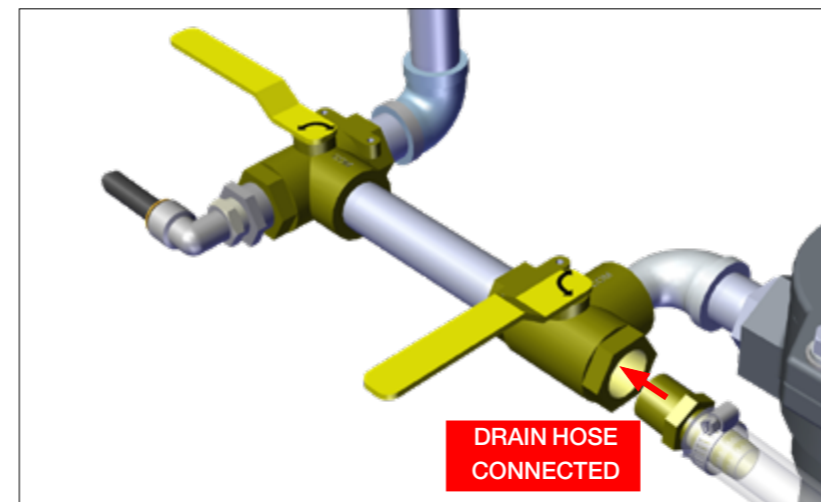
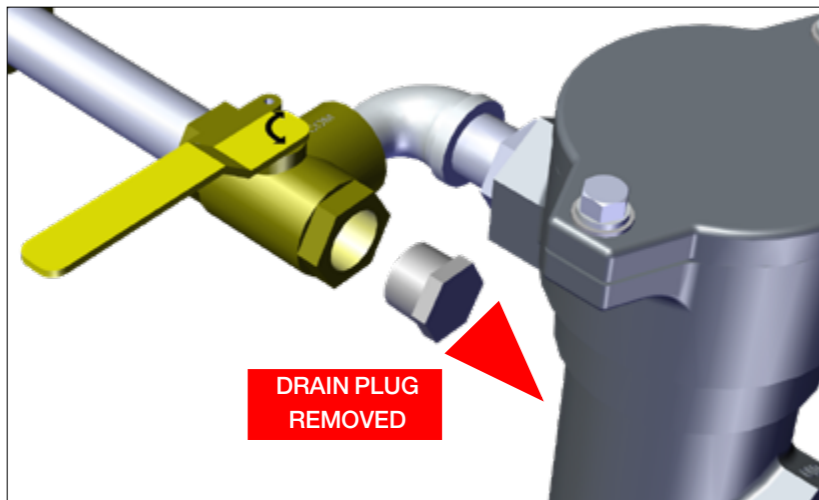

Step 4: Use a crescent wrench to remove the 3/4" Pipe Plug under the Drain Valve.

- Connect a hose with 3/4" Male fitting to the Drain Valve and feed the other end into a waste receptacle.
- Waste receptacle must be large enough to contain at least the amount of water in the Supply Tank!

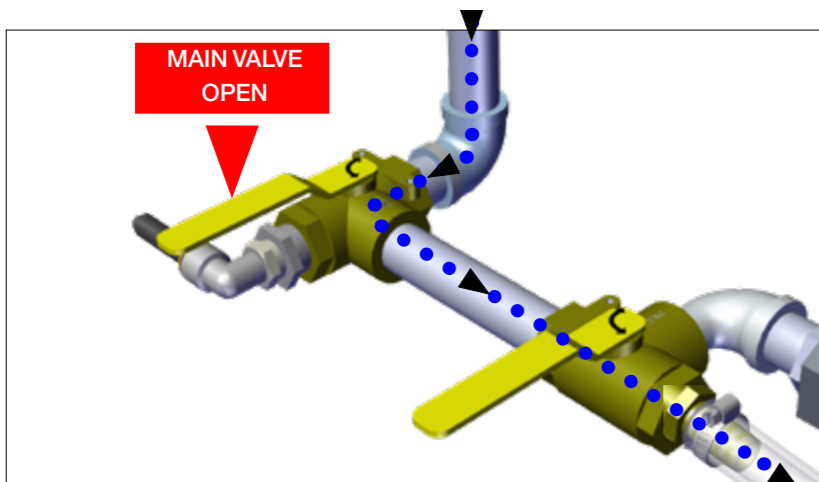

Step 5: Open the Main Supply Valve under the Supply Tank.

- Supply Tank empties into waste receptacle by force of gravity (Tank bottom is curvilinear and self-draining).

Continued ➞



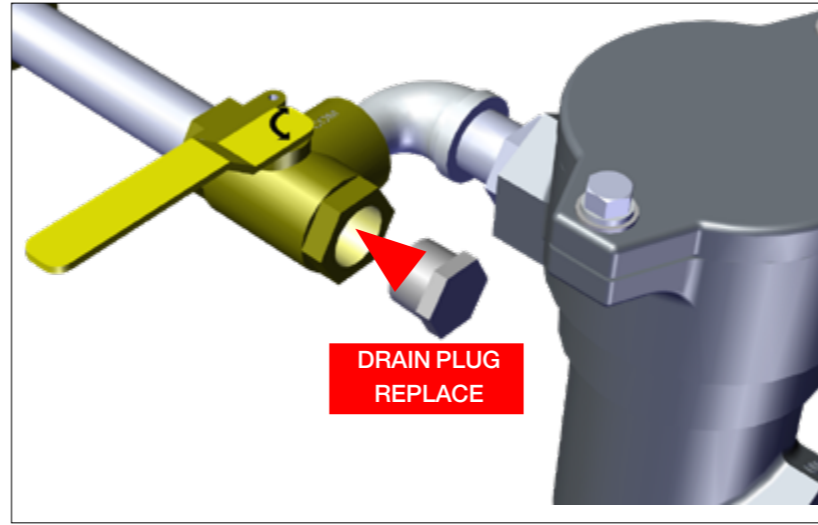
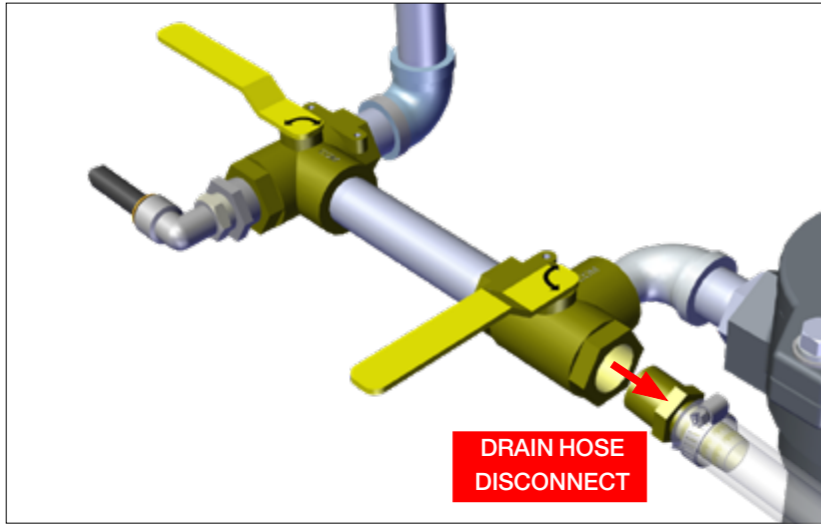

Step 6: Disconnect the hose with 3/4" Male fitting from the Drain Valve.

- Replace the 3/4" Pipe Plug on the Drain Valve.
- Use a crescent wrench to tighten in place.

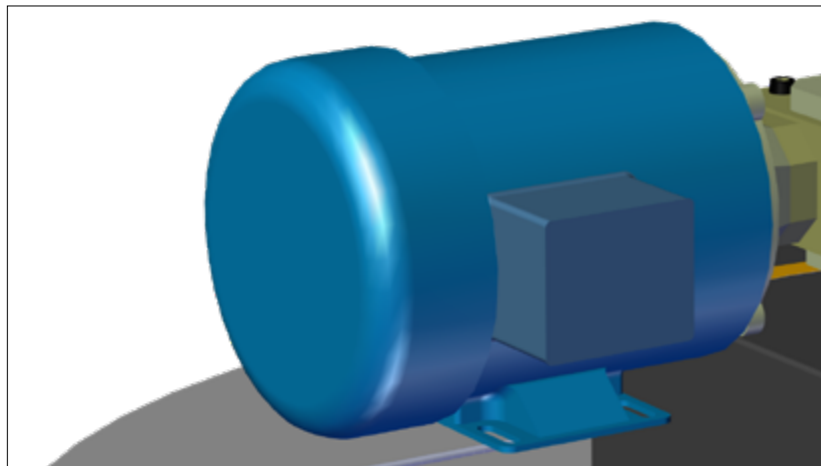

Step 7: Disconnect the PSD Tank Agitation Power Cord from an external power source.

- Tank agitation stops.



Note: Rinse water (gray water) from supply tank clean out procedures may be saved and used with the next slurry mix or disposed of properly, according to state and local regulations.

Failure to clean the supply tank properly, or failure to completely drain all liquid from the pump and lines after use, may damage the equipment and void any warranties expressed or implied.

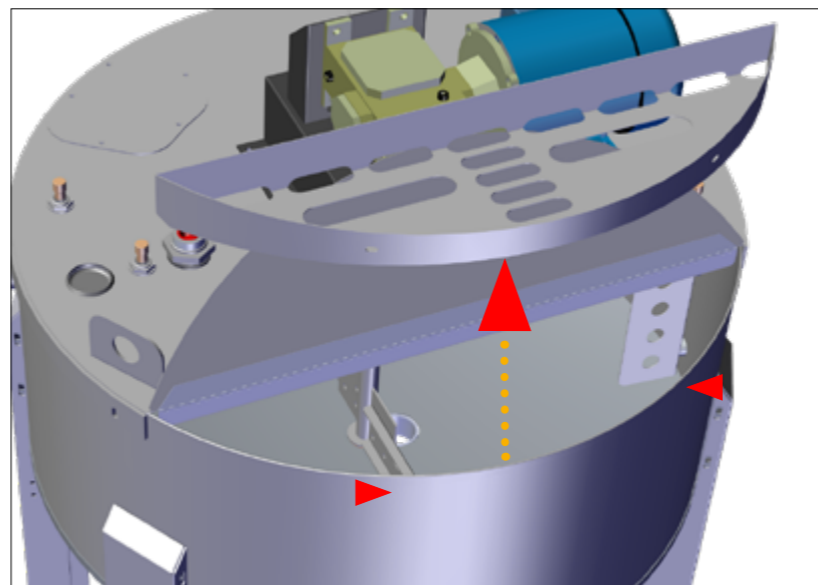
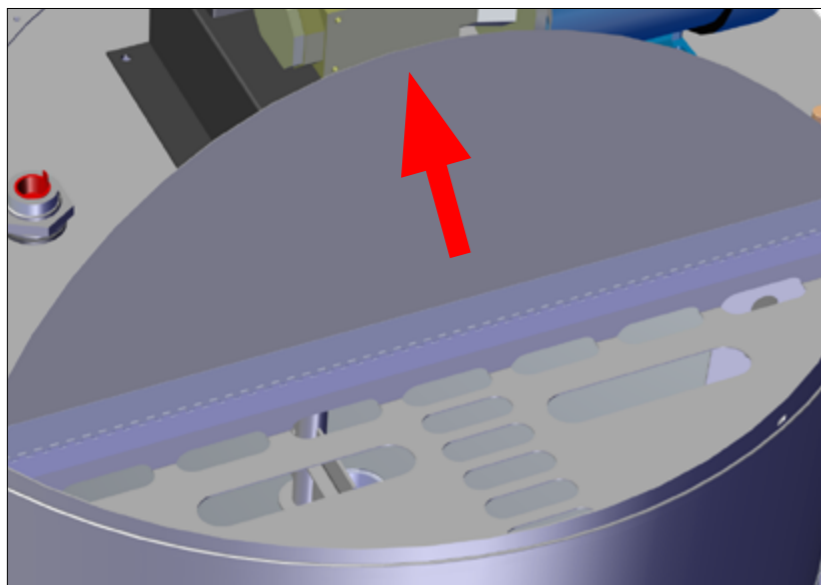

Step 8: Open Tank Lid.

- Use a 5/16" wrench to remove both 1/4-20 hardware and remove the Finger Guard.
- Use rags to wipe clean the Supply Tank interior.
- Discard rags responsibly.
- If needed, use a putty knife to scrape off any residual chemical buildup inside the Supply Tank.

This completes the Drain PSD Tank procedure.





TREATING HEAD



Warning! Exercise extreme caution when working with dust & chemicals! Wear proper PPE >>



Required tools

- 5/16" wrench
- Vacuum

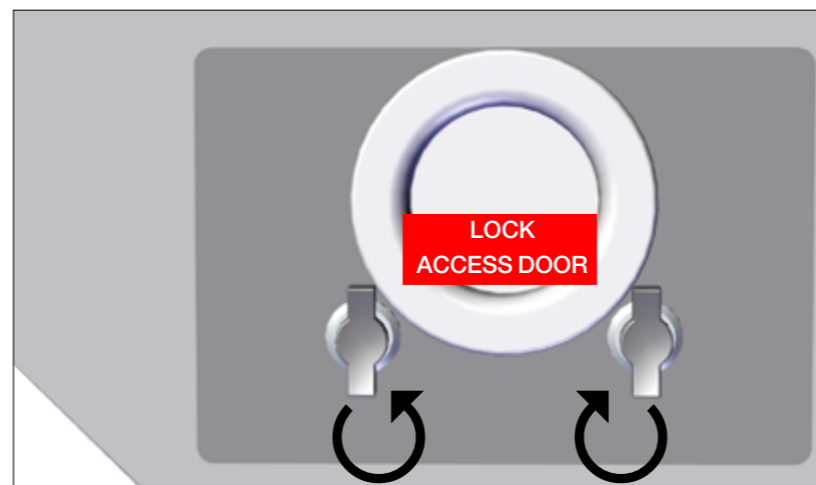
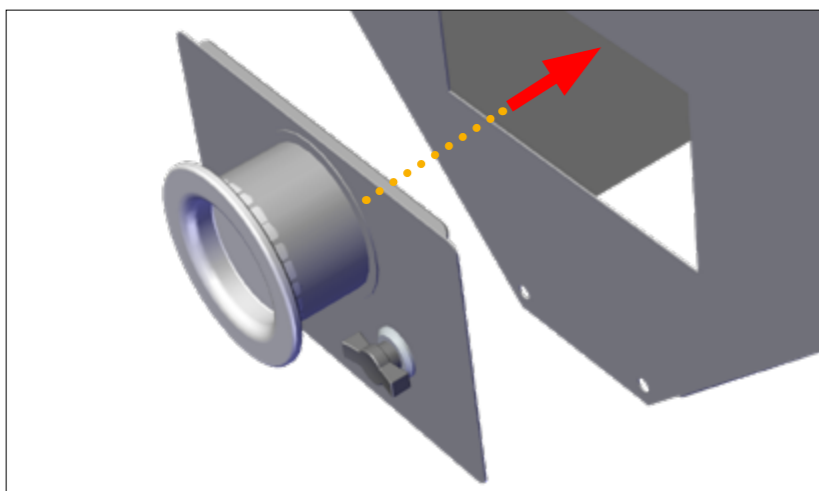
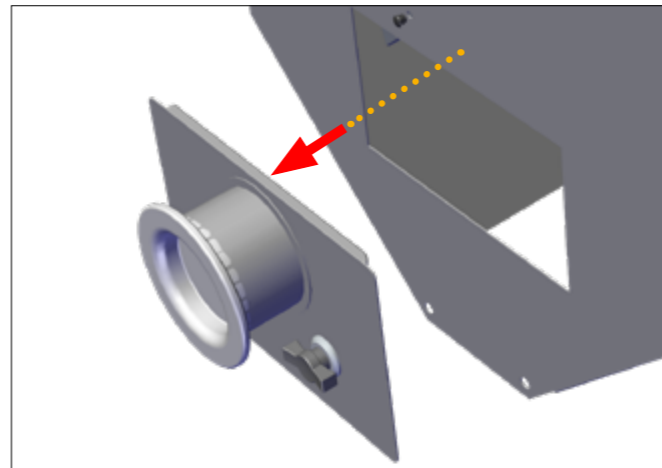

Weigh Pan Housing - Liquid System

Step 1: Turn both Plastic Handle Latches IN towards the middle to unlock the Weigh Pan Housing Access Door

- Remove the Weigh Pan Housing Access Door.
- Always use a vacuum (not compressed air) to safely clean the Weigh Pan Housing interior.
- Wear appropriate Personal Protective Equipment when working with dust and chemicals: goggles, dust mask, gloves and coveralls.

Step 2: Replace the Access Door when finished cleaning.

- Turn both Plastic Handle Latches **OUT** to lock the Access Door in place.

Continued ➡



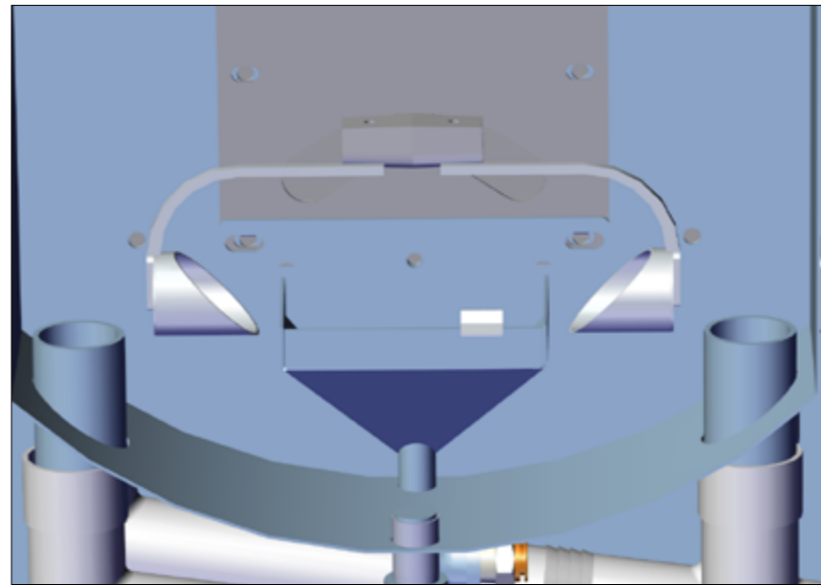
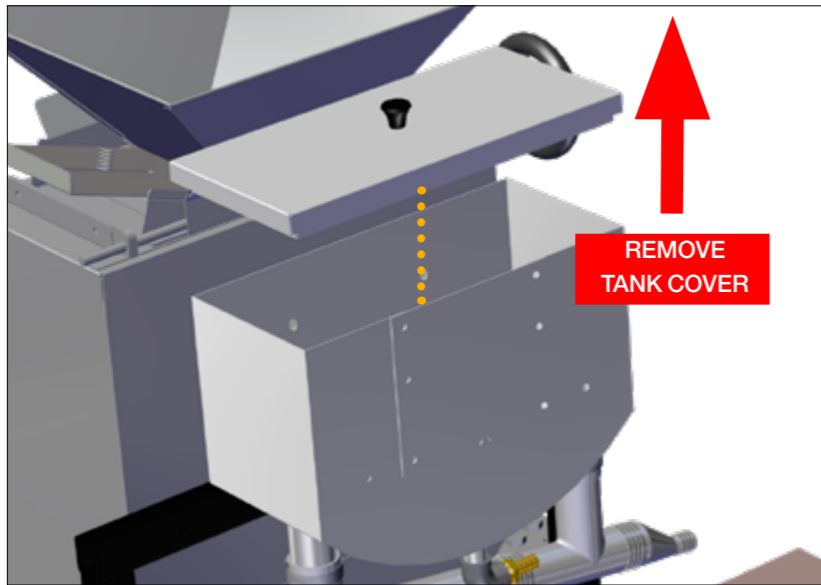

Metering Tank

Step 1: Remove the Metering Tank Cover.

- Use rags to wipe clean the Metering Tank interior and Chemical Cups.
- Discard rags responsibly.
- Replace the Metering Tank Cover.

Hopper Top Assembly

Step 1: Use a 5/16" wrench to remove the three (3) bolts that fasten the Hopper Top Assembly to the Weigh pan Housing.

- Remove the Hopper Top Assembly and vacuum inside the Weigh pan Housing.
- Replace the Hopper Top Assembly on the Weigh pan Housing and securely fasten in place.

This completes the Treating Head Cleaning procedure.

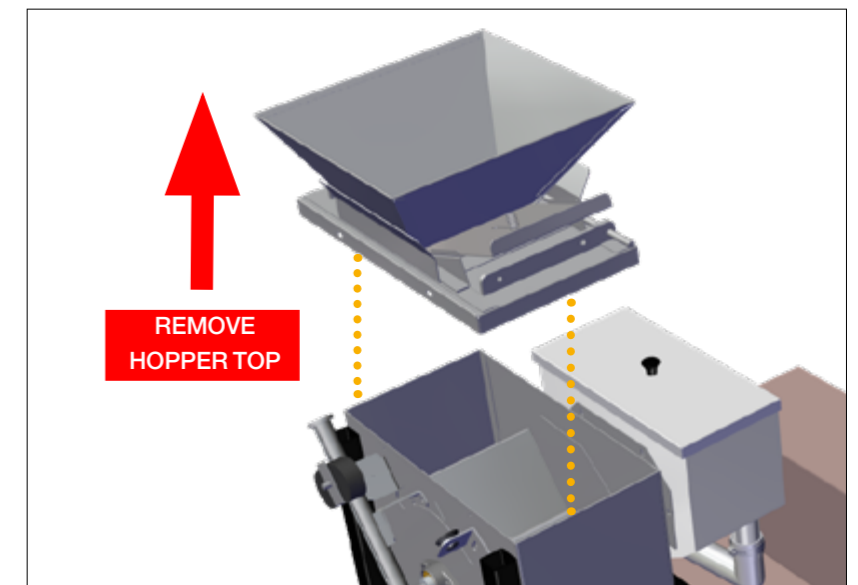
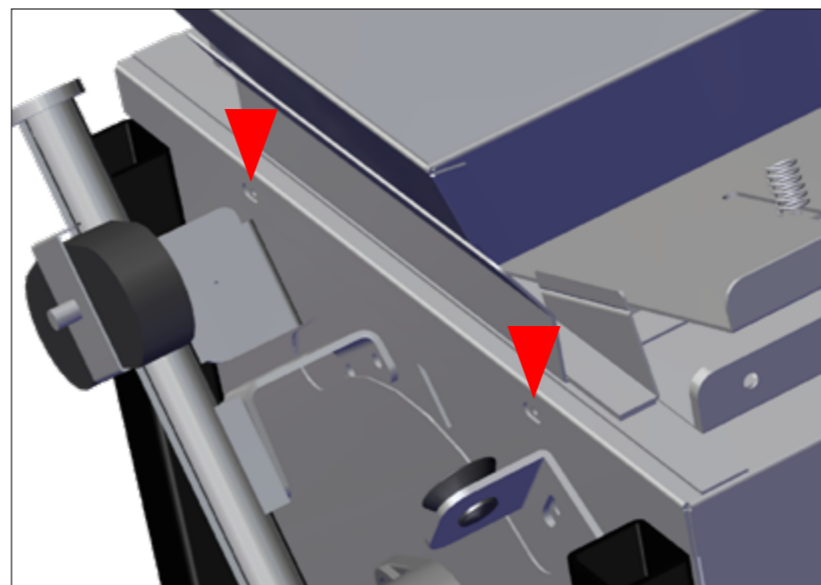
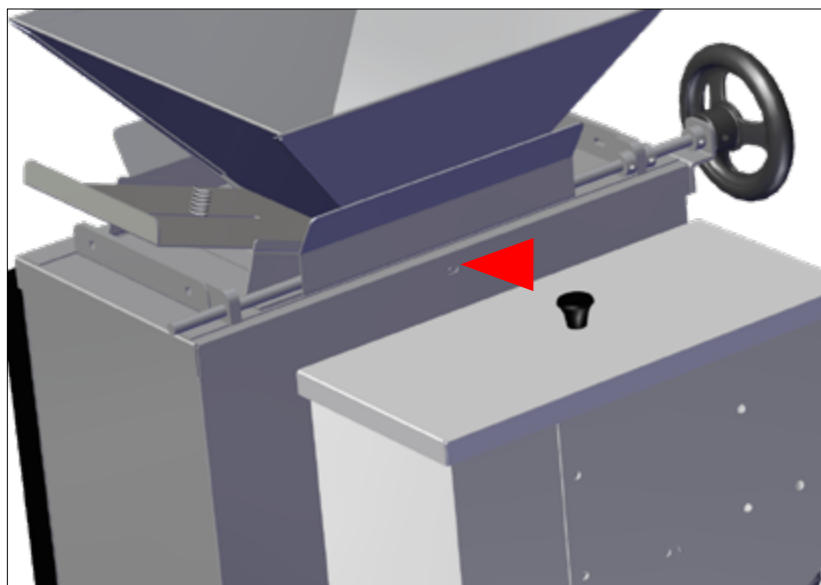



DRY DELIVERY SYSTEM



Warning! Exercise extreme caution when working with electricity! Ensure a licensed electrician open the Gear Motor conduit box and disconnect the power cord.

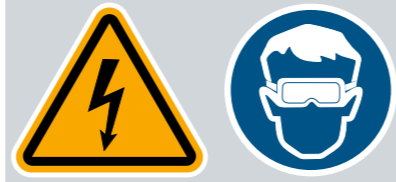

Required tools

- Phillips Screwdriver
- Vacuum
- ½" wrench

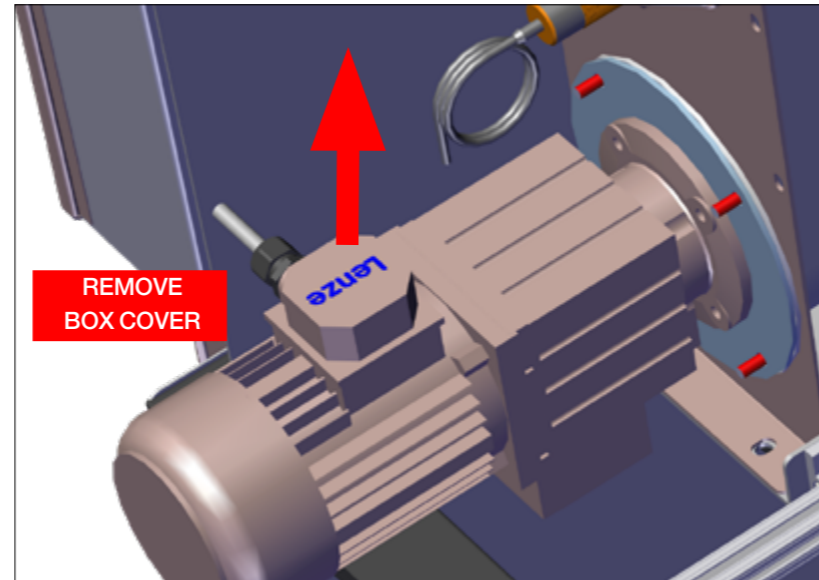
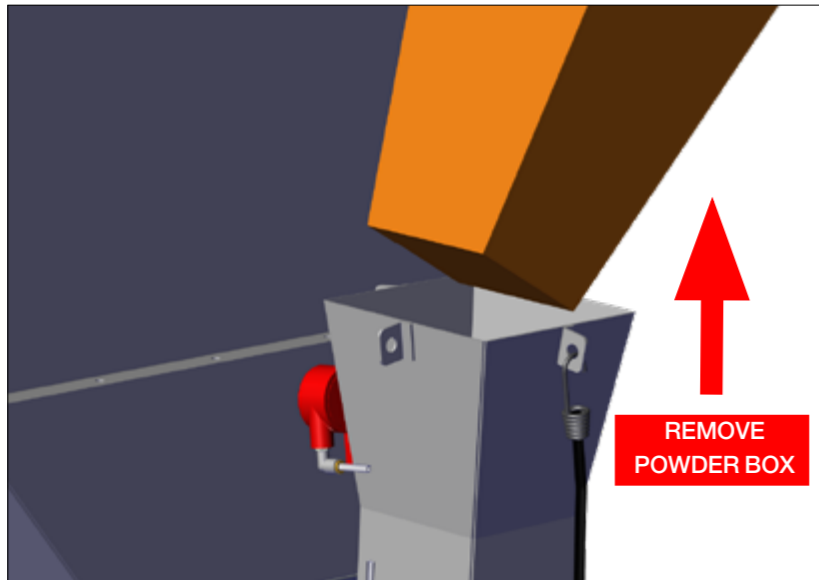

Powder Feeder - Pyramid Style

Step 1: At end of each treating session or whenever the operator needs to change powder product, run all of the existing powder out of the Powder Feeder.

- Remove the Pyramid Box out of the Powder Hopper.
- Since powder absorbs ambient air moisture and solidifies if left over time, internal Housing cleaning helps prevent powder “caking up”.
- Ensure a licensed electrician opens the Gear Motor conduit box and disconnects the DDS power cord.

Continued ➡



Step 2: Use 1/2" wrench to remove the four bolts that hold the Adapter Plate, Gasket and Gear Motor onto the backside of the Powder Base.

- Remove the Gear Motor (with the Auger and gasket still attached) from the Powder Body and set aside.

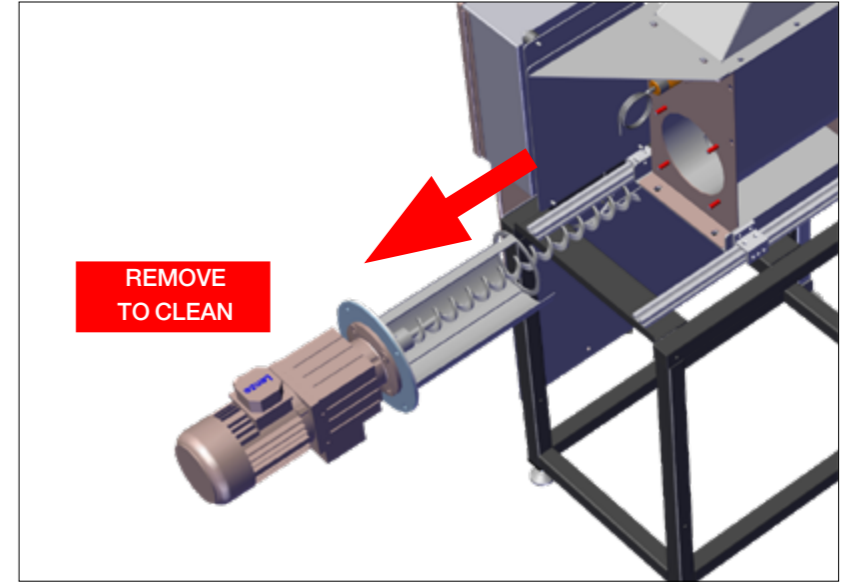
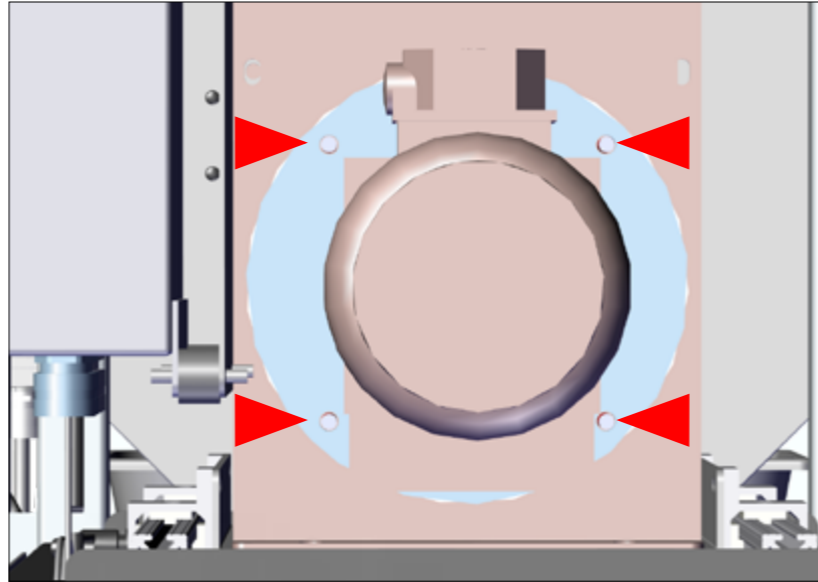
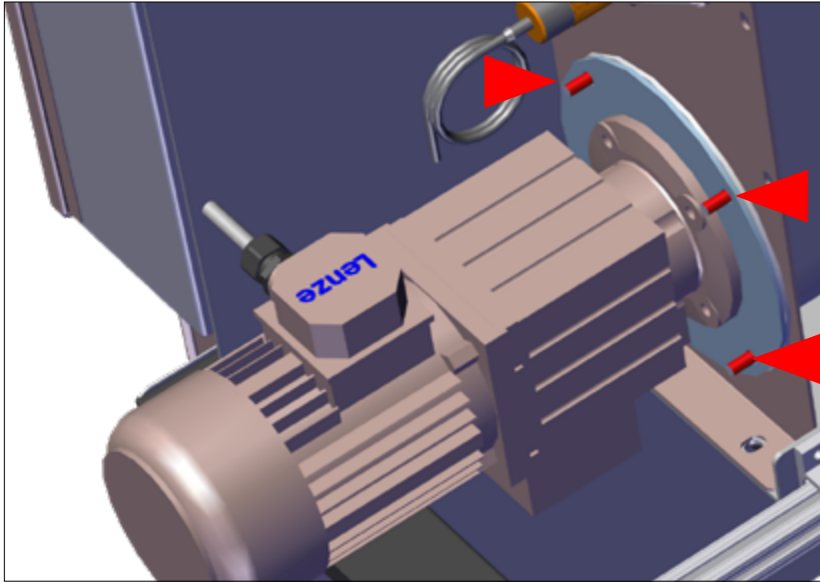

Step 3: Vacuum any powder build-up on the Auger Assembly.

- Vacuum any powder build-up inside the Powder Body and Powder Hopper.
- When ready to use, replace the Gear Motor and Auger.
- Tighten hardware securely with 1/2" wrench.
- Connect the Gear Motor power cord and replace the conduit box cover.

This completes the Dry Delivery System Cleaning procedure.

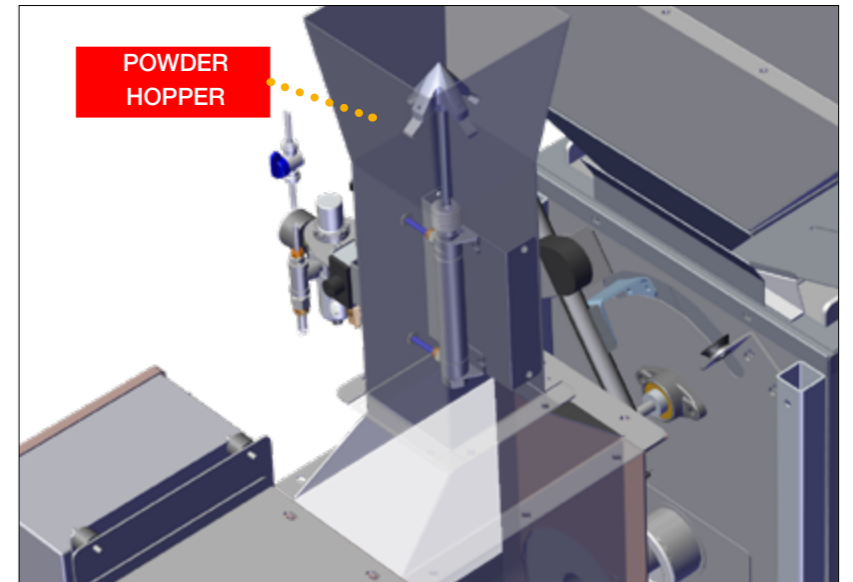
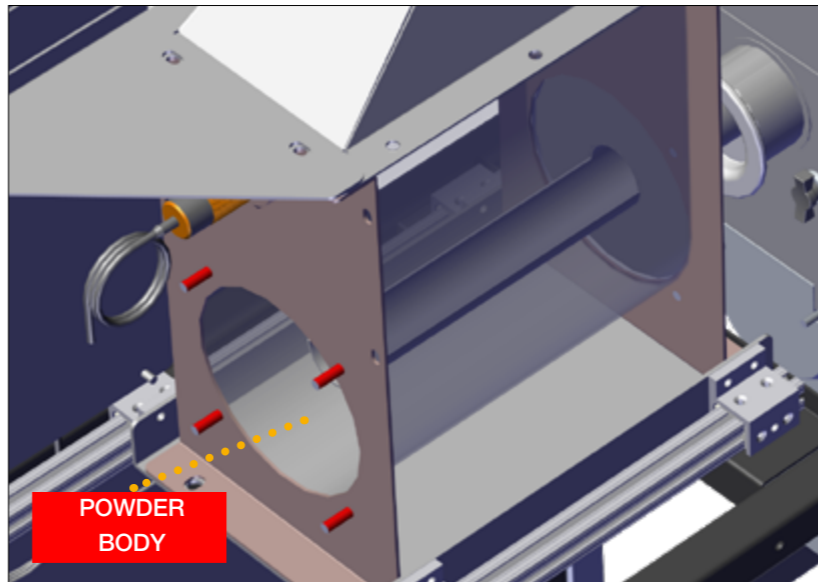
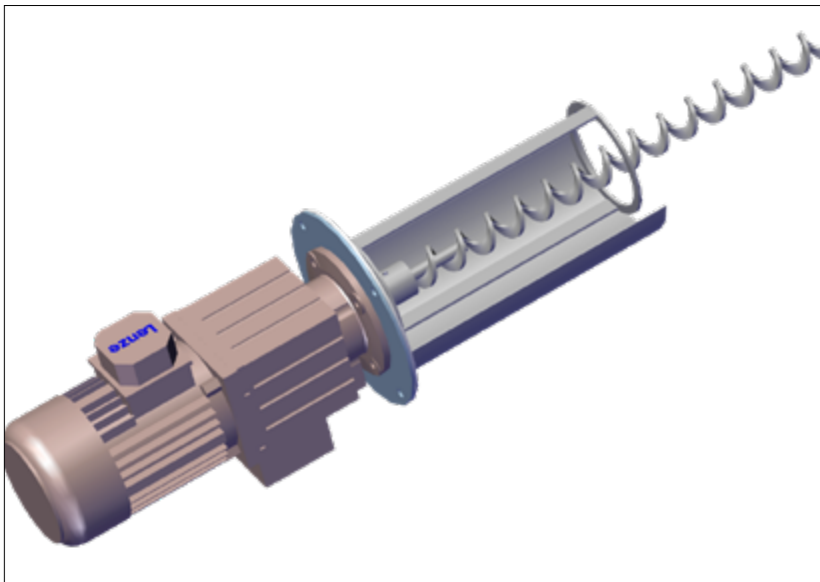



POWDER FEEDER



Warning! Exercise extreme caution when working with electricity! Ensure a licensed electrician open the Gear Motor conduit box and disconnect the power cord.

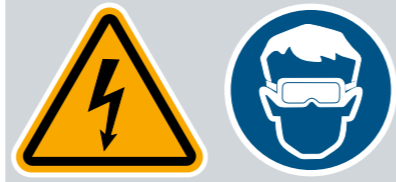

Required tools

- Phillips Screwdriver
- Vacuum
- ½" wrench

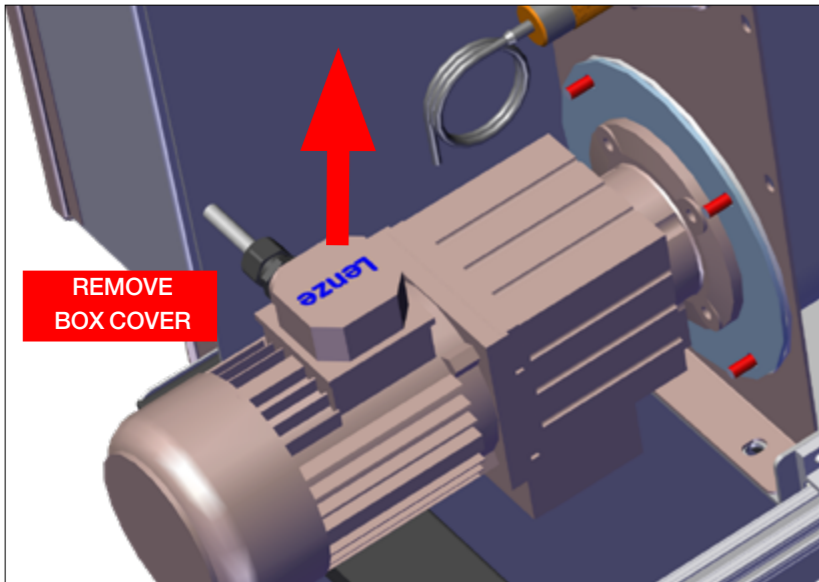

Powder Feeder - Hopper Style

Step 1: At end of each treating session or whenever the operator needs to change powder product, run all of the existing powder out of the Powder Feeder.

- Since powder absorbs ambient air moisture and solidifies if left over time, internal Housing cleaning helps prevent powder “caking up”.
- Ensure a licensed electrician opens the Gear Motor conduit box and disconnects the Powder Feeder power cord.

Continued ➔



Step 2: Use 1/2" wrench to remove the four (4) bolts that hold the Adapter Plate, Gasket and Gear Motor onto the backside of the Powder Base.

- Remove the Gear Motor (with the Auger and gasket still attached) from the Powder Body and set aside.

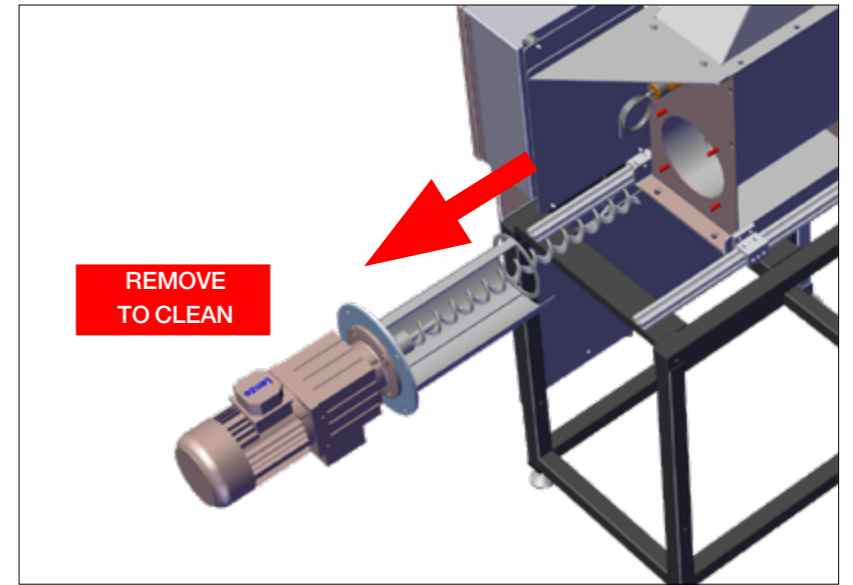
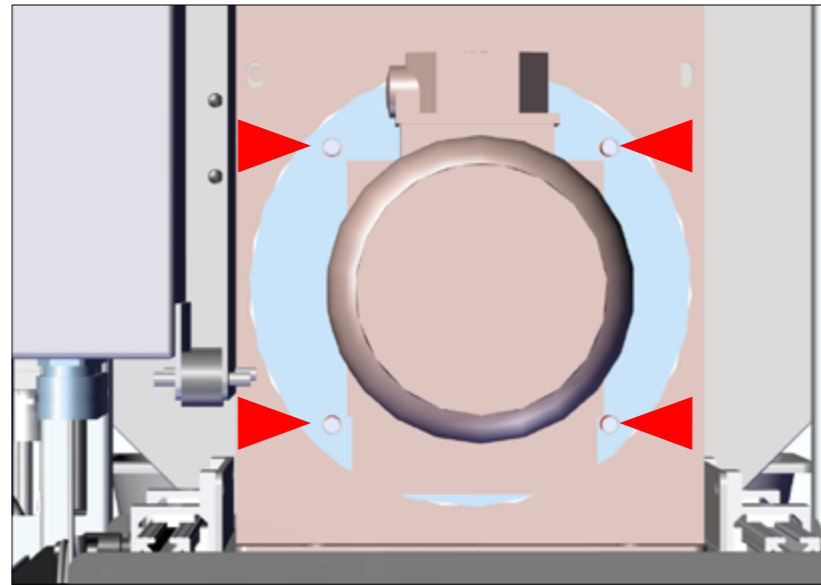
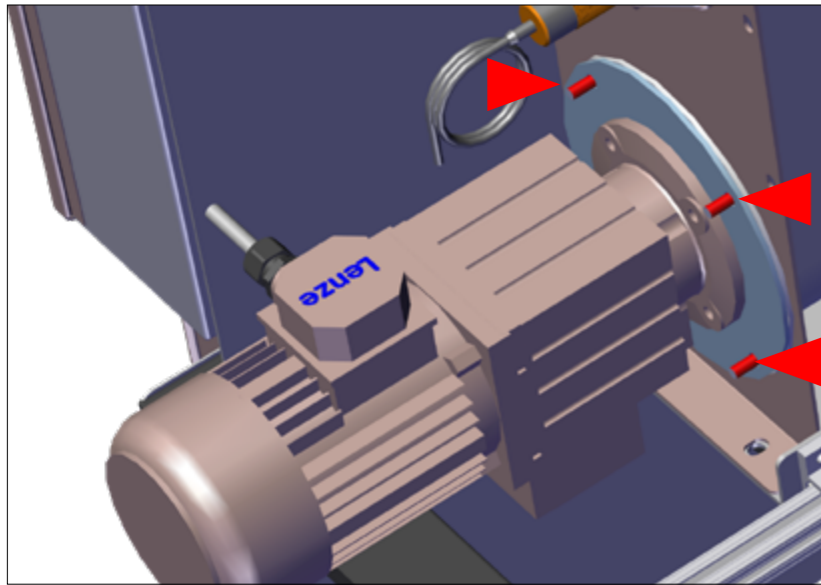

Step 3: Vacuum any powder build-up on the Auger Assembly.

- Vacuum any powder build-up inside the Powder Body and Powder Hopper.
- When ready to use, replace the Gear Motor and Auger.
- Tighten hardware securely with 1/2" wrench.
- Connect the Gear Motor power cord and replace the conduit box cover.

This completes the Powder Feeder Cleaning procedure.

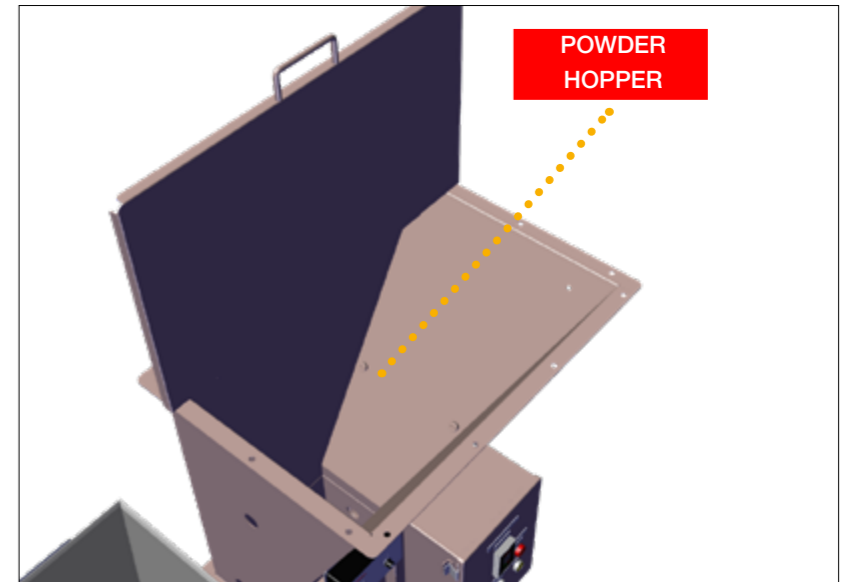
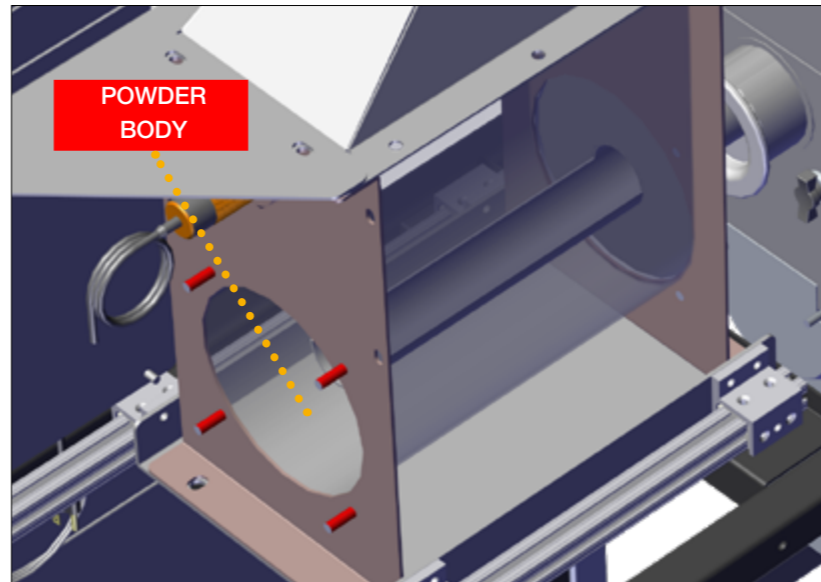
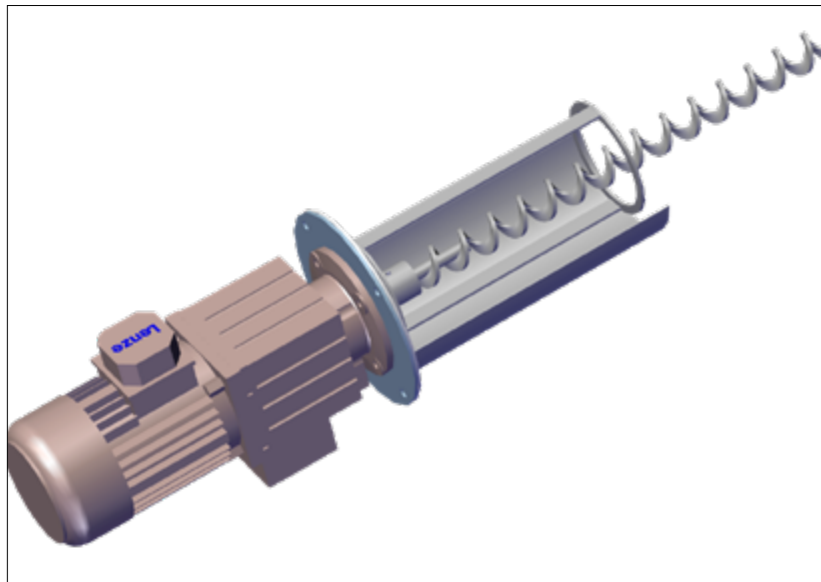



Bayer

Crop Science Division
1451 Dean Lakes Trail
Shakopee, MN 5379
USA

Telephone

+1-952-445-6868

Toll free:

+1-855-363-3152

Visit us on:

www.seedgrowth.bayer.com

Bayer™ and the Bayer Cross™ are registered trademarks of Bayer.

AMPDMAINTENANCE20211015

